

03 February 2015

Hansen Architectural Systems
5500 SE Alexander ST
Hillsboro, OR 97124

SUBJ: CLEARVUE RAILING
ALUMINUM RAILING
PICKET, CABLE AND GLASS INFILL SYSTEMS
SERIES 100, 200, 300, 350 AND 400 SERIES SYSTEMS

The ClearVue Railing System (CVR) utilizes aluminum extrusions and glass infill to construct building guards and rails for decks, balconies, stairs, fences and similar locations. The system is intended for interior and exterior weather exposed applications and is suitable for use in all natural environments. The CVR may be used for residential, commercial and industrial applications. The CVR is an engineered system designed for the following criteria:

The design loading conditions are:

On Top Rail:

Concentrated load = 200 lbs any direction, any location

Uniform load = 50 plf, any perpendicular to rail

On In-fill Panels:

Concentrated load = 50# on one sf.

Distributed load = 25 psf on area of in-fill, including spaces

Wind load = 28.5 psf typical installation (higher wind loads may be allowed based on post spacing and anchorage method)

Refer to IBC Section 1607.7.1 for loading.

The CVR system will meet or exceed all requirements of the 2000, 2003, 2006, 2009 and 2012 *International Building Codes* and *International Residential Codes*, and state building codes based on these versions of the IBC, and 2005 and 2010 *Aluminum Design Manual*. Wood components and anchorage to wood are designed in accordance with the 2012 *National Design Specification for Wood Construction*.

Edward Robison, P.E.

EDWARD C. ROBISON, PE
10012 Creviston Dr NW
Gig Harbor, WA 98329
253-858-0855/Fax 253-858-0856 elrobison@narrows.com

Typical Installations:

Refer to *Guard Posts Mounted To Wood Decks Residential Installations 42" Guard Height* report for other details and mounting requirements for mounting to wood framing in compliance with the 2009 IBC and 2009 IRC.

Surface mounted with base plates:

Residential Applications:

Rail Height 36" or 42" above finish floor.

Standard Post spacing 6' on center maximum.

Bottom rail intermediate post required over 5'.

All top rails

Commercial and Industrial Applications:

Rail Height 42" above finish floor.

Standard Post spacing 5' on center maximum.

All top rails

Core pocket /embedded posts or stainless steel stanchion mounted:

Residential Applications:

Rail Height 36" or 42" above finish floor.

Standard Post spacing 6' on center maximum, series 100

8' on center Series 200, 300, 350 and 400.

Bottom rail intermediate post required over 5'.

Commercial and Industrial Applications:

Rail Height 42" above finish floor.

Standard Post spacing 6' on center maximum, series 100

6' on center Series 200, 300, 350 and 400.

Contents:	Page:	Contents:	Page:
Signature/Stamp Page	3	Picket Infills	54 - 57
Load Cases	4	Grab Rails and Brackets	57 - 61
Wind loading	5	Cable Infills	62 - 72
Glass Infill	6 - 9		
Posts and mountings	10 - 27		
Series 100	28 - 31		
Top Rails	32 - 43		
Bottom Rails	44 - 45		
Mid Rails	46 - 47		
Rail Connection Block	48		
Rail End Caps	49 - 50		
Wood Fastener Tables	51 - 53		

EDWARD C. ROBISON, PE

10012 Creviston Dr NW

Gig Harbor, WA 98329

253-858-0855/Fax 253-858-0856 elrobison@narrows.com

SIGNED:

EDWARD C. ROBISON, PE
10012 Creviston Dr NW
Gig Harbor, WA 98329
253-858-0855/Fax 253-858-0856 elrobison@narrows.com

LOAD CASES:

Glass rail Dead load = 5 plf for 42" rail height or less.

Loading:

Horizontal load to top rail from in-fill:

$$25 \text{ psf} \cdot H/2$$

Post moments

$$M_i = 25 \text{ psf} \cdot H \cdot S \cdot H/2 = \\ = 12.5 \cdot S \cdot H^2$$

For top rail loads:

$$M_c = 200\# \cdot H$$

$$M_u = 50\text{plf} \cdot S \cdot H$$

For wind load surface area:

$$M_w = w \text{ psf} \cdot H \cdot S \cdot H \cdot 0.55 = \\ = 0.55w \cdot S \cdot H^2$$

Solving for w :

$$w = M/(0.55 \cdot S \cdot H^2)$$

Wind load equivalent for 42" rail height, 5' post spacing 50 plf top rail load:

$$M_u = 50\text{plf} \cdot 5' \cdot 3.5' = 875\# \cdot 3.5' = 10,500\# \cdot 3.5'$$

$$w = 875/(0.55 \cdot 5 \cdot 3.5^2) = 26 \text{ psf}$$

Allowable wind load adjustment for other post spacing:

$$w = 26 \cdot (5/S)$$

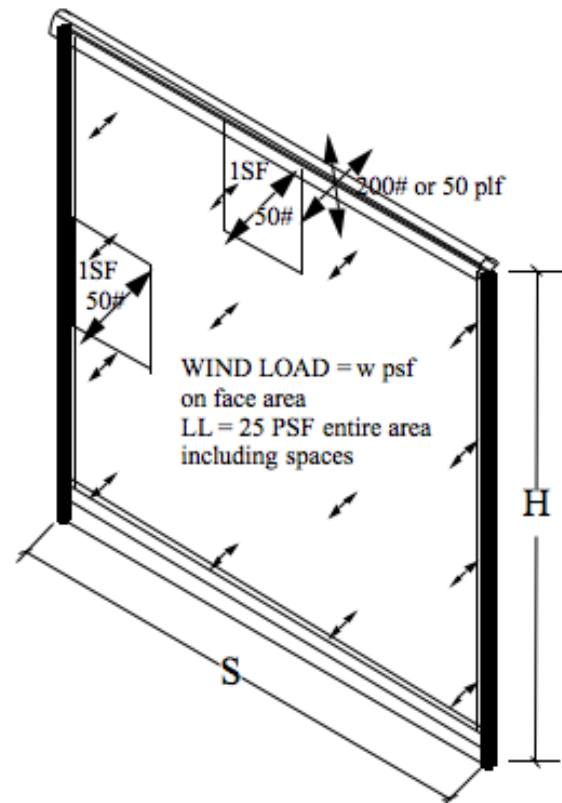

EDWARD C. ROBISON, PE

10012 Creviston Dr NW

Gig Harbor, WA 98329

253-858-0855/Fax 253-858-0856 elrobison@narrows.com

WIND LOADING

For wind load surface area is full area of guard:

Calculated in accordance with ASCE/SEI 7-05 Section 6.5.14 *Design Wind Loads on Solid Freestanding Walls and Solid Signs (or ASCE/SEI 7-10 Chapter 29.4)*. This section is applicable for free standing building guardrails, wind walls and balcony railings that return to building walls. Section 6.5.12.4.4 (29.6) *Parapets* may be applicable when the rail is along a roof perimeter. **Wind loads must be determined by a qualified individual for a specific installation.**

$$p = q_p(GC_p) = q_zGC_f \text{ (ASCE 7-05 eq. 6-26 or 7-10 eq. 29.4-1)}$$

$$G = 0.85 \text{ from section 6.5.8.2 (sec 26.9.4.)}$$

$$C_f = 2.5 * 0.8 * 0.6 = 1.2 \text{ Figure 6-20 (29.4-1) with reduction for solid and end returns, will vary.}$$

$$Q_z = K_z K_{zt} K_d V^2 I \text{ Where:}$$

$$I = 1.0$$

K_z from Table 6-3 (29.3-1) at the height z of the railing centroid and exposure.

$$K_d = 0.85 \text{ from Table 6-4 (Table 26-6).}$$

K_{zt} From Figure 6-4 (Fig 26.8-1) for the site topography, typically 1.0.

V = Wind speed (mph) 3 second gust, Figure 6-1 (Fig 26.5-1A) or per local authority.

Simplifying - Assuming $1.3 \leq C_f \leq 2.6$ (Typical limits for fence or guard with returns.)

$$\text{For } C_f = 1.3: F = q_h * 0.85 * 1.3 = 1.11 q_h$$

$$\text{For } C_f = 2.6: F = q_h * 0.85 * 2.6 = 2.21 q_h$$

Wind Load will vary along length of fence in accordance with ASCE 7-05 Figure 6-20 (29.4-1).

Typical exposure factors for K_z with height 0 to 15' above grade:

Exposure	B	C	D
$K_z =$	0.70	0.85	1.03

MINIMUM WIND LOAD TO BE USED IS 10 PSF.

Centroid of wind load acts at 0.55h on the fence.

Typical wind load range for $I = 1.0$ and $K_{zt} = 1.0$

Table 1: Wind Speed V	Wind load in psf $C_f = 1.3$			Wind load in psf $C_f = 2.60$		
	B	C	D	B	C	D
	$0.00169V^2$	$0.00205V^2$	$0.00249V^2$	$0.00337V^2$	$0.00409V^2$	$0.00495V^2$
85	12.2	14.8	17.9	24.3	29.5	35.8
90	13.7	16.6	20.2	27.3	33.1	40.1
100	16.9	20.5	24.9	33.7	36.9	49.5
110	20.5	24.8	30.1	40.7	49.5	59.9
120	24.3	29.6	35.8	48.5	58.9	71.3
130	28.6	34.7	42.0	56.9	69.1	83.7
140	33.1	40.2	48.8	66.0	80.1	97.1

Where guard ends without a return the wind forces may be as much as 1.667 times $C_f=2.6$ value.

When $I = 0.87$ is applicable (occupancy category I) multiply above loads by 0.87.

For wind loads based on ASCE 7-10 wind speeds, figures 26.5-1A, B and C, multiply the wind loads by 0.6 to convert to Allowable Stress Design loads.

For example - Exp B with $C_f = 1.3$; 7-05 wind speed = 85 mph $w = 12.2$ psf:

7-10 wind speed = 110mph $w = 0.6 * 20.5 = 12.3$ psf (ASD wind loads used herein)

EDWARD C. ROBISON, PE

10012 Creviston Dr NW

Gig Harbor, WA 98329

253-858-0855/Fax 253-858-0856 elrobison@narrows.com

GLASS STRENGTH FULLY TEMPERED INFILL PANELS

All glass is fully tempered glass conforming to the specifications of ANSI Z97.1, ASTM C 1048-97b and CPSC 16 CFR 1201. The average Modulus of Rupture for the glass F_r is 24,000 psi. In accordance with UBC 2406.6 or IBC 2407.1.1 glass used as structural balustrade panels shall be designed for a safety factor of 4.0. This is applicable only to structural panels (glass provides support to railing). Glass not used in guardrails may be designed for a safety factor of 2.5 in accordance with ASTM E1300-12a.

Values for the modulus of rupture, F_R , modulus of Elasticity, E and shear modulus, G for glass are typically taken as (see AAMA CW-12-84 *Structural Properties of Glass*) :

$$F_R = 24,000 \text{ psi.}$$

$E = 10,400 \text{ ksi.}$ While the value of E for glass varies with the stress and load duration this value is typically used as an average value for the stress range of interest. I

$G = 3,800 \text{ ksi:}$ This is rarely used when checking the deflection in glass. The shear component of the deflection tends to be very small, under 1% of the bending component and is therefore ignored.

$$\mu = 0.22 \text{ (Typical value of Poisson's ratio for common glasses.)}$$

The safety factor of 4 is dictated by the building code (IBC 2407.1.1). It is applied to the modulus of rupture since glass as an inelastic material does not have a yield point.

There is no deflection limits for the glass in guards other than practical limits for the opening sizes, retention in the frames and occupant comfort. Refer to ASTM E 1300-12a for a standard method of calculating deflections but the deflection limits are concerned with glazing in windows and similar parts of the building envelope rather than a free standing guard. IBC 2403.3 applies a limit of $L/175$ or $3/4''$ for the supporting frame. From IBC Table 1604.3 footnote h similar types of construction have a limit of $L/60$. ICC AC 273 *Acceptance Criteria for Handrails and Guards* paragraph 4.2.4 applies a deflection limit of $h/12$ to the posts and $L/96$ to the top rail.

The shear strength of glass tracks closely to the modulus of rupture because failure under shear load will be a tensile failure with strength limited by the modulus of rupture. Thus shear loads are transformed using Mohr's circle to determine the critical tension stress to evaluate the failure load. The safety factor of 4 is applicable to this case same as the bending case. Thus the shear stress is limited based on principal stresses of 0 and 6,000 psi to $6,000/2 = 3,000 \text{ psi.}$ Bearing stress can be derived in a similar fashion with the principal stresses being $-6,000 \text{ psi}$ and $6,000 \text{ psi}$ so the bearing stress = $6,000 \text{ psi.}$

Bending strength of glass for the given thickness:

$$I = 12'' \cdot (t)^3 / 12 = (t)^3 \text{ in}^3/\text{ft}$$

$$S = 12'' \cdot (t)^2 / 6 = 2 \cdot (t)^2 \text{ in}^3/\text{ft}$$

For lites simply supported on two opposite sides the moment and deflection are calculated from basic beam theory

EDWARD C. ROBISON, PE

10012 Creviston Dr NW

Gig Harbor, WA 98329

253-858-0855/Fax 253-858-0856 elrobison@narrows.com

$M_w = W*L^2/8$ for uniform load W and span L or

$M_p = P*L/4$ for concentrated load P and span L, highest moment P @ center

Maximum wind loads:

$W = M_a*8/L^2$ for uniform load W and span L (rail to rail distance)

Deflection can be calculated using basic beam theory:

$\Delta = (1-v^2)5wL^4/(384EI)$ for uniform load

For concentrated load:

$\Delta = (1-v^2) PL^3/(48EI)$

Maximum allowable deflection: Use L/60 deflection limit for infill. This will prevent glass from deflecting enough to disengage from the frame.

For uniform load (wind load)

Solving for w

$w = [t^3*1.676*10^8]/L^3$

Solving for L

$L = [(t^3*1.676*10^8)/w]^{1/3}$

Solving for t

$t = [L^3w/(1.676*10^8)]^{1/3}$

For Concentrated load

Solving for P

$P = (8.74*10^6t^3)/L^2$

Solving for L

$L = [8.74*10^6*t^3/P]^{1/2}$

Solving for t

$t = [PL^2/(8.74*10^6)]^{1/3}$

EDWARD C. ROBISON, PE

10012 Creviston Dr NW

Gig Harbor, WA 98329

253-858-0855/Fax 253-858-0856 elrobison@narrows.com

From IBC 2407 the minimum nominal glass thickness for infill panels in guards is 1/4"

1/4" FULLY TEMPERED GLASS

Weight = 2.89 psi

$t_{ave} = 0.223''$

For 1/4" glass $S = 2*(0.223)^2 = 0.0995 \text{ in}^3/\text{ft}$

$M_{allowable} = 6,000\text{psi} * 0.0995 \text{ in}^3/\text{ft} = 597\text{#}''/\text{ft}$

For FS = 3.0 (no fall hazard, glass fence or wind screen)

$M_{all} = 597\text{#}'' * 4/3 = 796\text{#}''$

Moment for 36" wide lite (infill for 42" rail height) 25 psf or 50 lb load

$M_w = 25\text{psf} * 3'^2 * 12'' / 8 = 337.5\text{#}''$

$M_p = 50 * 36'' / 4 = 450\text{#}''$

Moment for 42" wide lite (infill for 48" rail height) 25 psf or 50 lb load

$M_w = 25\text{psf} * 3.5'^2 * 12'' / 8 = 459.4\text{#}''$

$M_p = 50 * 42'' / 4 = 525\text{#}''$

for 36" wide lite (infill for 42" rail height)

$W = 597\text{#}'' * 8 / (3' * 36'') = 44 \text{ psf}$

for 42" wide lite (infill for 48" rail height)

$W = 597\text{#}'' * 8 / (3.5' * 42'') = 32.5 \text{ psf}$

Deflection:

36" wide lite (infill for 42" rail height) 25 psf or 50 lb load

$L/60 = 36/60 = 0.60$

$\Delta = [(1 - 0.222^2) * 25 * 36^4 / 0.25^3] / (9.58 \times 10^9) = 0.27''$

or $\Delta = (1 - 0.222^2) * 50 * 36^3 / (4.992 * 10^8 * 0.25^3) = 0.285''$

EDWARD C. ROBISON, PE

10012 Creviston Dr NW

Gig Harbor, WA 98329

253-858-0855/Fax 253-858-0856 elrobison@narrows.com

3/8" FULLY TEMPERED GLASS

Weight = 4.75 psi

$t_{ave} = 0.366''$

For 3/8" glass $S = 2*(0.366)^2 = 0.268 \text{ in}^3/\text{ft}$

$M_{allowable} = 6,000\text{psi}*0.268 \text{ in}^3/\text{ft} = 1,607\text{#}''/\text{ft}$

For FS = 3.0 (no fall hazard, glass fence or wind screen)

$M_{all} = 1,607\text{#}''*4/3 = 2,143\text{#}''$

Moment for 36" wide lite (infill for 42" rail height) 25 psf or 50 lb load

$M_w = 25\text{psf}*3'^2*12''/8 = 337.5\text{#}''$

$M_p = 50*36''/4 = 450\text{#}''$

Moment for 42" wide lite (infill for 48" rail height) 25 psf or 50 lb load

$M_w = 25\text{psf}*3.5'^2*12''/8 = 459.4\text{#}''$

$M_p = 50*42''/4 = 525\text{#}''$

for 36" wide lite (infill for 42" rail height)

$W = 1,607\text{#}''*8/(3'*36'') = 119 \text{ psf}$

for 42" wide lite (infill for 48" rail height)

$W = 1,607\text{#}''*8/(3.5'*42'') = 87.5 \text{ psf}$

Deflection:

36" wide lite (infill for 42" rail height) 25 psf or 50 lb load

$L/60 = 36/60 = 0.60$

$\Delta = [(1-0.22^2)*25*36^4/0.366^3]/(9.58 \times 10^9) = 0.085''$

or $\Delta = (1-0.22^2)*50*36^3/(4.992*10^8*0.366^3) = 0.090''$

Check maximum wind load based on deflection:

36" width $w = [0.366^3*1.676*10^8]/36^3 = 175 \text{ psf}$ (does not control)

42" width $w = [0.366^3*1.676*10^8]/42^3 = 110 \text{ psf}$ (does not control)

EDWARD C. ROBISON, PE

10012 Creviston Dr NW

Gig Harbor, WA 98329

253-858-0855/Fax 253-858-0856 elrobison@narrows.com

2-3/8" Square Post

6061-T6 Aluminum

Post

-Area 0.995"

 $I_{xx} = I_{yy} = 0.863 \text{ in}^4$

$$S = 0.726 \text{ in}^3$$

$$r = 0.923 \text{ in}$$

$$J = 0.98 \text{ in}$$

 $k \leq 1$ for all applications

Allowable bending stress ADM Table 2-21

$$S_1 = \frac{L_B S_C}{0.5 (I_y J)^{1/2}} = \frac{L_B \cdot 0.726}{0.5 (0.863 \cdot 0.98)^{1/2}} = 1.58 L_B$$

$$\text{for } L_B \leq \frac{146}{158} = 92'' \rightarrow F_{CB} = 21 \text{ ksi}$$

$$\text{for } L_B > 92'' F_{CB} = 2.39 - 0.24(1.58 L_B)^{1/2}$$

$$M_{all} = 0.726 \cdot 19 \text{ ksi} = 13,794 \text{ #''} = 1,149.5 \text{ #ft}$$

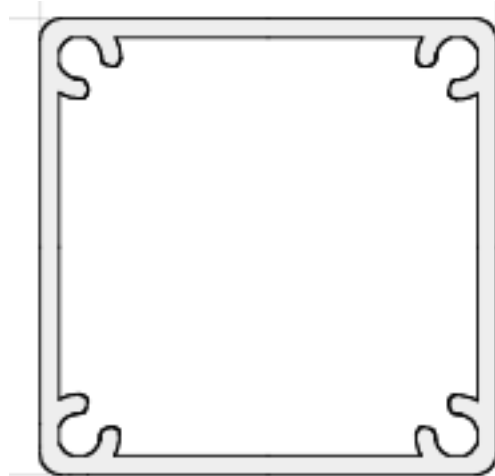

POST EXTRUSION 2-3/8" square

EDWARD C. ROBISON, PE

10012 Creviston Dr NW

Gig Harbor, WA 98329

253-858-0855/Fax 253-858-0856 elrobison@narrows.com

Post 45° Corner

6061-T6

Post Section Properties

-Area 1.261"

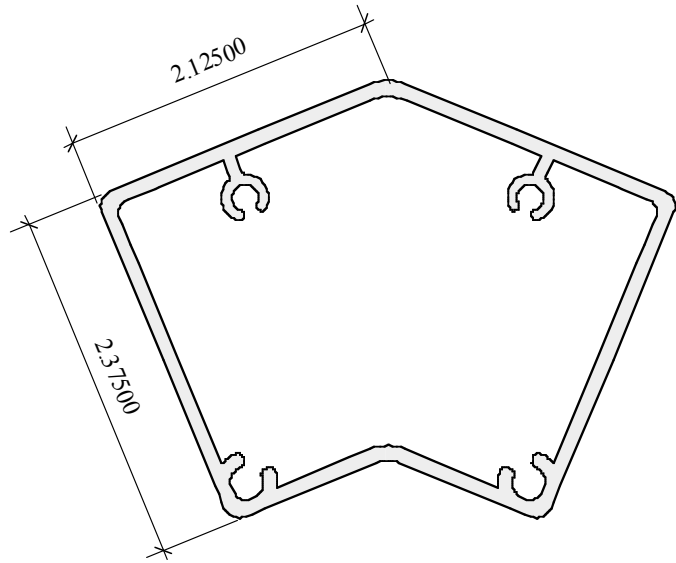
 $I_{xx} = 1.120 \text{ in}^4$ $I_{yy} = 1.742 \text{ in}^4$ $S_{xx} = 0.812 \text{ in}^3$ $S_{yy} = 0.900 \text{ in}^3$ $r_{xx} = 0.975 \text{ in}$ $r_{yy} = 1.175 \text{ in}$ $J = 1.146 \text{ in}$ $k = 1$ for all applications

Allowable bending stress **ADM Table 2-21**

$$S_1 = \frac{L_B S_C}{0.5 \sqrt{I_y J}} = \frac{L_B \cdot 0.900}{0.5 \sqrt{(1.120 \cdot 1.146)}} = 1.58 L_B$$

$$\text{for } L_B \leq \frac{146}{1.58} = 92'' \rightarrow F_{CB} = 21 \text{ ksi}$$

$$\text{for } L_B > 92'' F_{CB} = 2.39 - 0.24(1.58 L_B)^{1/2}$$

$$M_{all} = 0.812 \cdot 19 \text{ ksi} = 15,428 \text{ #''} = 1,286 \text{ #ft}$$

Connection to base plate

Post uses standard base plate

EDWARD C. ROBISON, PE

10012 Creviston Dr NW

Gig Harbor, WA 98329

253-858-0855/Fax 253-858-0856 elrobison@narrows.com

Connection to base plate

Failure modes → screw tension
 → screw shear
 → screw withdrawal

For screw withdrawal

See ADM 5.4

From testing screw engagement in slot is adequate so that failure is consistently screw rupture without withdrawal from the slot.

Base plate to post screws are AISI 4037 steel alloy fabricated in accordance with SAE J429 Grade 8 and coated with Magni 550 corrosion protection. Refer to base plate attachment strength test report for determination of allowable screw tension strength and allowable moment on the connection.

Average failure moment = 22,226''#

Safety factor calculated in accordance with ADM 9.3.2 = 2.07

Allowable Moment on the base plate to post connection:

$$M_{\text{allowable}} = 22,226''\#/2.07 = 10,895''\#$$

Allowable screw tension load:

$$T_{\text{all}} = 10,895''\#/(2 \cdot 2.28'') = 2,389\# \text{ From testing}$$

Calculated strength:

Screw tension → $F_{tU} = 0.0376 \cdot 150 \text{ ksi} = 5,640\#$ Screw rupture on net tension area

For fracture $SF = 1.6/(0.9 \cdot 0.75) = 2.37 \rightarrow 5,640/2.37 = 2,380\#$

Using the calculated screw strength

$$M_{\text{all}} = 2 \cdot 2,380\# \cdot 2.28'' = 10,852''\#$$

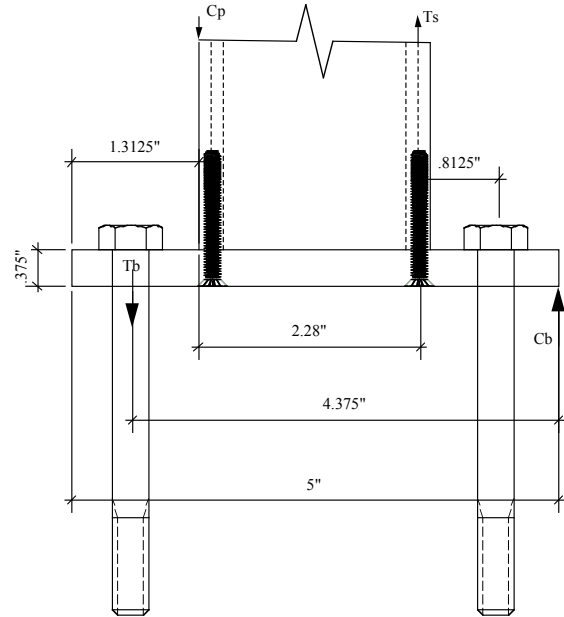

EDWARD C. ROBISON, PE

10012 Creviston Dr NW

Gig Harbor, WA 98329

253-858-0855/Fax 253-858-0856 elrobison@narrows.com

Base plate bending stress

$$F_t = 24 \text{ ksi} \rightarrow S_{\min} = \frac{5'' \cdot 3/8^2}{6} = 0.117 \text{ in}^3$$

Base plate allowable moment

$$M_{\text{all}} = 24 \text{ ksi} \cdot 0.117 \text{ in}^3 = 2,812 \text{ \#''}$$

→ Base plate bending stress

$$T_B = C$$

$$M = 0.8125'' \cdot T_B \cdot 2$$

$$T_{\text{all}} = \frac{2,812}{2 \cdot 0.8125} = 1,730 \text{ \#}$$

Maximum post moment for base plate strength

$$M_{\text{all}} = 2 \cdot 1,730 \cdot 4.375'' = 15,142 \text{ \#''}$$

Limiting factor = screws to post

$$M_{\text{ult}} = 2 \cdot 5,314 \text{ \#} \cdot 2.28'' = 24,232 \text{ \#''}$$

$$M_{\text{all}} = 2 \cdot 2,293 \text{ \#} \cdot 2.28'' = 10,500 \text{ \#''}$$

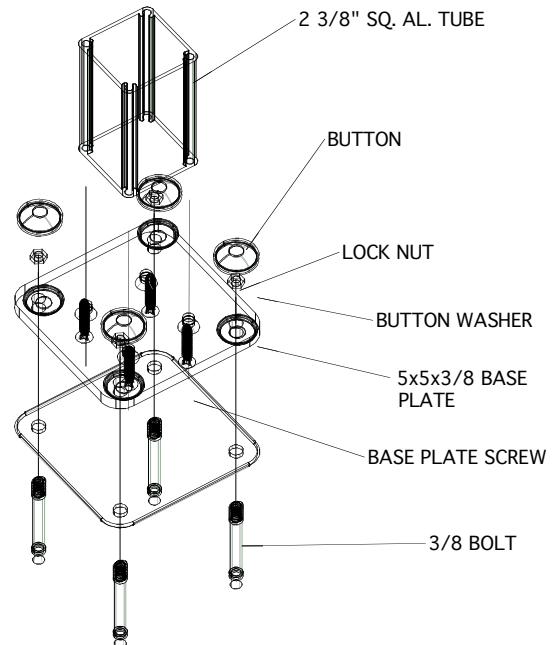

Refer to *Guard Rail Post To Base Plate Screw Connection Strength* report dated 11/22/2010 by this engineer for testing results. Testing has confirmed that screws fail in tension and not pullout from the screw slot, 2010 ADM J5.5.1.2 equation J5-7 is not applicable based on testing.

For factors of safety refer to Aluminum Design Manual Section 5.3.2.1 and SEI/ASCE 8-02 section 5

BASE PLATE ANCHORAGE

$$T_{\text{Des}} = \frac{10,500}{2 \cdot 4.375''} = 1,195 \text{ \#}$$

adjustment for concrete bearing pressure:

$$a = 2 \cdot 1,195 / (2 \cdot 3000 \text{ psi} \cdot 4.75'') = 0.087''$$

$$T'_{\text{Des}} = \frac{10,500}{2 \cdot (4.375'' - 0.087/2)} = 1,206 \text{ \#}$$

For 200# top load and 42'' post ht

$$T_{200} = \frac{8,400}{2 \cdot 4.375''} = 960 \text{ \#}$$

For 42'' post height the maximum live load at the top of the post is:

$$P_{\text{max}} = 10,500 \text{ \#} / 42'' = 250 \text{ \#}$$

For 50 plf live load maximum post spacing is:

$$S_{\text{max}} = 250 \text{ \#} / 50 \text{ plf} = 5' = 5'0''$$

EDWARD C. ROBISON, PE

10012 Creviston Dr NW

Gig Harbor, WA 98329

253-858-0855/Fax 253-858-0856 elrobison@narrows.com

RAISED BASEPLATE DESIGN AND ANCHORAGE –

Baseplates are raised up and bear on nuts installed on epoxy anchored threaded rod.

Guard rail Height: 42”

loading: 200# concentrated load or

50 plf uniform load on top

rail or

25 psf distributed load on

area or

25 psf = 80 mph exp C wind

load:

Design moment on posts:

$$M_l = 42'' * 200\# = 8,400''\#$$

$$M_u = 42'' * 50\text{plf} * 5\text{ft} = 10,500''\#$$

$$M_w = 3.5' * 5' * 25\text{psf} * 42'' / 2 = 9,188''\#$$

Design anchorage for 10,500''# moment.

Design shear = 438# (wind)

Bolt tension for typical design

$$T = 10,500 / (2 * 3.75) = 1,400\#$$

Anchor to concrete:

3/8” x 5” all-thread embedment depth = 3.5” and 4,000 psi concrete strength.

Allowable loads taken from ER-5560,

$$T = 2,700\# \quad \text{Adjustment for anchor spacing} = 3.75''$$

$$C_s @ 3.75'' = 1 - 0.20[(5.625 - 3.75) / 4.5] = 0.917$$

Adjustment for edge distance = 2-1/8”

$$C_e = 1 - 0.30[(3.375 - 2.125) / 2.25] = 0.833$$

$$T' = 2,700\# * 0.917 * 0.833 = 2,062\#$$

Check base plate strength: Bending is biaxial because it sits on bearing nuts:

$$M = (3.75'' - 2.28'') / 2 * 1,400\# * 2 * \sqrt{2} = 2,910''\#$$

Bending stress in plate

The effective width at the post screws: 3.86”

$$S = 2 * 3.86'' * 0.375^2 / 6 = 0.181 \text{ in}^3$$

$$f_b = 2,910 / 0.181 = 16,080 \text{ psi}$$

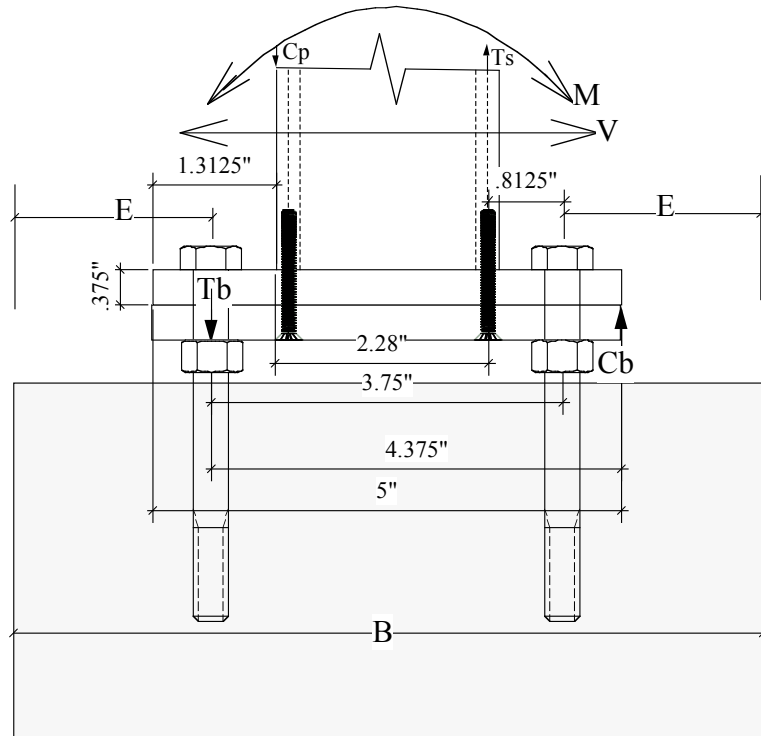

EDWARD C. ROBISON, PE

10012 Creviston Dr NW

Gig Harbor, WA 98329

253-858-0855/Fax 253-858-0856 elrobison@narrows.com

Allowable = 19 ksi

Bearing on nut:

$$\text{Area} = (0.8^2 - 0.5625^2)\pi = 1.0 \text{ in}^2$$

$$f_B = 1,400\#/1.0 = 1,400 \text{ psi} - \text{Okay}$$

Screws to post – okay based on standard base plate design

Posts okay based on standard post design

OFFSET BASE PLATE

Offset base plate will have same allowable loads as the standard base plate.

Anchors to concrete are same as for standard base plate.

BASEPLATE MOUNTED TO WOOD – SINGLE FAMILY RESIDENCE

For 200# top load and 36" post height: $M =$

$$200\# \times 36" = 7,200\#\text{'}$$

$$T_{200} = \frac{7,200}{2 \times 4.375"} = 823\#$$

Adjustment for wood bearing:

Bearing Area Factor:

$$C_b = (5" + 0.375)/5" = 1.075$$

$$a = 2 \times 823 / (1.075 \times 625 \text{ psi} \times 5") = 0.49"$$

$$T = 7,200 / [2 \times (4.375 - 0.49/2)] = 872\#$$

Required embed depth:

For protected installations the minimum embedment is:

$$l_e = 872\# / 323\#/\text{in} = 2.70" : +7/32" \text{ for tip} = 2.92"$$

For weather exposed installations the minimum embedment is:

$$l_e = 872\# / 243\#/\text{in} = 3.59" : +7/32" \text{ for tip} = 3.81"$$

FOR WEATHER EXPOSED INSTALLATIONS USE 5" LAG SCREWS AND INCREASE BLOCKING TO 4.5" MINIMUM THICKNESS.

REFER TO *GUARD POSTS MOUNTED TO WOOD DECKS RESIDENTIAL INSTALLATIONS 42" GUARD HEIGHT* REPORT FOR OTHER DETAILS AND MOUNTING REQUIREMENTS FOR MOUNTING TO WOOD FRAMING. MAY BE USED FOR COMMERCIAL APPLICATIONS AT 4' POST SPACING.

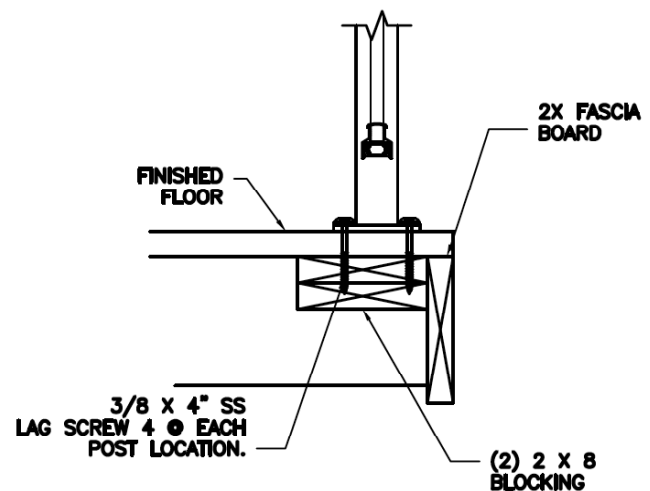

EDWARD C. ROBISON, PE

10012 Creviston Dr NW

Gig Harbor, WA 98329

253-858-0855/Fax 253-858-0856 elrobison@narrows.com

BASE PLATE MOUNTED TO CONCRETE - Expansion Bolt Alternative:

Base plate mounted to concrete with ITW Red Head Trubolt wedge anchor 3/8"x3.75" concrete anchors with 3" effective embedment. Anchor strength based on ESR-2427

Minimum conditions used for the calculations:

$$f'_c \geq 3,000 \text{ psi}$$

$$\text{edge distance} = 2.25'' \quad \text{spacing} = 3.75''$$

$$h = 3.0'' : \text{embed depth}$$

For concrete breakout strength:

$$N_{cb} = [A_{Ncg}/A_{Nco}] \phi_{ed,N} \phi_{c,N} \phi_{cp,N} N_b$$

$$A_{Ncg} = (1.5 \cdot 3 \cdot 2 + 3.75) \cdot (1.5 \cdot 3 + 2.25) = 86.06 \text{ in}^2 \quad 2 \text{ anchors}$$

$$A_{Nco} = 9 \cdot 3^2 = 81 \text{ in}^2$$

$$C_{a,cmin} = 1.5'' \quad (\text{ESR-2427 Table 3})$$

$$C_{ac} = 5.25'' \quad (\text{ESR-2427 Table 3})$$

$$\phi_{ed,N} = 1.0$$

$$\phi_{c,N} = (\text{use } 1.0 \text{ in calculations with } k = 24)$$

$$\phi_{cp,N} = \max(1.5/5.25 \text{ or } 1.5 \cdot 3 / 5.25) = 0.857 \quad (c_{a,min} \leq C_{ac})$$

$$N_b = 24 \cdot 1.0 \cdot \sqrt{3000} \cdot 3.0^{1.5} = 6,830 \#$$

$$N_{cb} = 86.06/81 \cdot 1.0 \cdot 1.0 \cdot 0.857 \cdot 6,830 = 6,219 \leq 2 \cdot 4,200$$

based on concrete breakout strength.

Determine allowable tension load on anchor pair

$$T_s = 0.65 \cdot 6,219 \# / 1.6 = 2,526 \#$$

Check shear strength - Concrete breakout strength in shear:

$$V_{cb} = A_{vc}/A_{vco} (\phi_{ed,V} \phi_{c,V} \phi_{h,V} V_b)$$

$$A_{vc} = (1.5 \cdot 3 \cdot 2 + 3.75) \cdot (2.25 \cdot 1.5) = 43.03$$

$$A_{vco} = 4.5 (c_{a1})^2 = 4.5 (3)^2 = 40.5$$

$$\phi_{ed,V} = 1.0 \quad (\text{affected by only one edge})$$

$$\phi_{c,V} = 1.4 \text{ uncracked concrete}$$

$$\phi_{h,V} = \sqrt{(1.5 c_{a1} / h_a)} = \sqrt{(1.5 \cdot 3 / 3)} = 1.225$$

$$V_b = [7 (l_e / d_a)^{0.2} \sqrt{d_a}] \lambda \sqrt{f'_c} (c_{a1})^{1.5} = [7 (1.625 / 0.375)^{0.2} \sqrt{0.375}] 1.0 \sqrt{3000} (3.0)^{1.5} = 1,636 \#$$

$$V_{cb} = 43.03 / 40.5 \cdot 1.0 \cdot 1.4 \cdot 1.225 \cdot 1,636 \# = 2,981 \#$$

$$\text{Steel shear strength} = 1,830 \# \cdot 2 = 3,660$$

Allowable shear strength

$$\phi V_N / 1.6 = 0.70 \cdot 2,981 \# / 1.6 = 1,304 \#$$

$$\text{Shear load} = 250 / 1,304 = 0.19 \leq 0.2$$

Therefore interaction of shear and tension will not reduce allowable tension load:

$$M_a = 2,526 \# \cdot 4.375'' = 11,053 \#'' > 10,500 \#''$$

DEVELOPS FULL BASEPLATE MOUNTING STRENGTH.

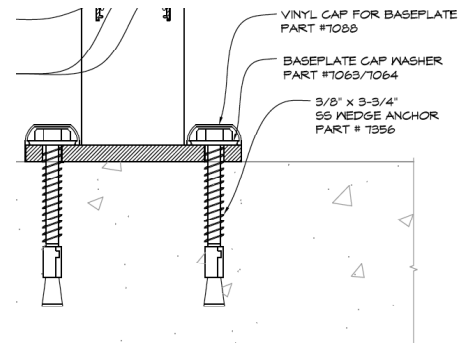

ALLOWABLE SUBSTITUTIONS: Use same size anchor and embedment

Hilti Kwik Bolt TZ in accordance with ESR-1917

Powers Power Stud+ SD2 in accordance with ESR-2502

Powers Wedge-Bolt+ in accordance with ESR-2526

EDWARD C. ROBISON, PE

10012 Creviston Dr NW

Gig Harbor, WA 98329

253-858-0855/Fax 253-858-0856 elrobison@narrows.com

Core Mounted Posts

Mounted in either 4"x4"x4" blockout, or 4" to 6" dia by 4" deep cored hole.

Core mount okay for 6' post spacing.
Assumed concrete strength 2500 psi for existing concrete

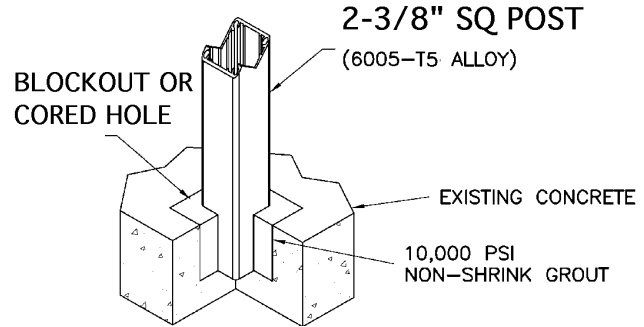

Max load – 6' • 50 plf = 300#

M = 300# • 42" = 12,600" #

Check grout reactions

From $\Sigma M_{PL} = 0$

$$P_U = \frac{12,600" \# + 300\# \cdot 3.33"}{2.67"} = 5093\#$$

$$f_{Bmax} = \frac{5093\# \cdot 2 \cdot 1/0.85}{2" \cdot 2.375"} = 2523 \text{ psi post to grout}$$

$$f_{Bconc} = 2523 \cdot 2"/4" = 1262 \text{ psi grout to concrete}$$

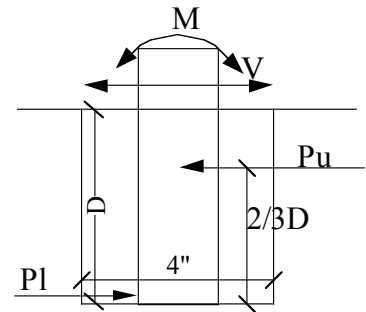

Pryout strength based on ACI 318-08 Appendix D:

For concrete breakout strength:

$$N_{cb} = [A_{Ncg}/A_{Nco}] \phi_{ed,N} \phi_{c,N} \phi_{cp,N} N_b$$

$$A_{Ncg} = (3" + 1.5 \cdot 4") \cdot (2 \cdot 1.5 \cdot 4" + 2.375) = 129.375$$

$$A_{Nco} = 9 \cdot 4^2 = 144 \text{ in}^2$$

$$C_{a,cmin} = 3"$$

$$C_{ac} = 2.5 \cdot 4" = 10"$$

$$\phi_{ed,N} = 1.0$$

$$\phi_{c,N} = 1.0 \text{ cracked}$$

$$\phi_{cp,N} = \max(3/10 \text{ or } 1.5 \cdot 3"/10) = 0.45 \text{ (} c_{a,min} \leq c_{ac} \text{)}$$

$$N_b = 17 \cdot 1.0 \cdot 1.0 \cdot \sqrt{3000} \cdot 4.0^{1.5} = 7,449\#$$

$$N_{cb} = 129.375/144 \cdot 1.0 \cdot 1.0 \cdot 0.45 \cdot 7,449 = 3,012$$

$$\text{Pryout} = 2 \cdot 3,012 = 6,023\#$$

$$V_b = [7(l_e/d_a)^{0.2} \sqrt{d_a}] \lambda \sqrt{f'_c} (c_{a1})^{1.5} = [7(4/2.375)^{0.2} \sqrt{2.375}] 1.0 \sqrt{3000} (4.0)^{1.5} = 5,246\#$$

$$V_{cb} = 1.0 \cdot 1.4 \cdot 1.0 \cdot 1.0 \cdot 5,246\# = 7,345\#$$

$$\phi M_n = 0.7 \cdot 7,345 \cdot 4" = 20,566" \# \geq 1.6 \cdot 12,600" \# = 20,160" \#$$

EDWARD C. ROBISON, PE

10012 Creviston Dr NW

Gig Harbor, WA 98329

253-858-0855/Fax 253-858-0856 elrobison@narrows.com

SIX SCREW POST – 2-3/8” Square

Post Strength

6005-T5 or 6061-T6

Post

-Area 1.1482”

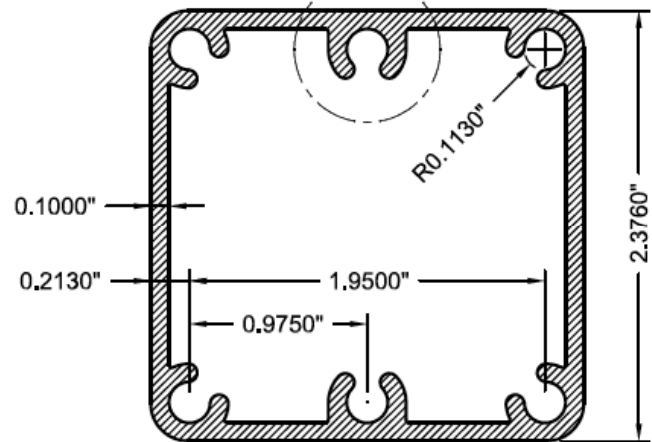
 $I_{xx} = 0.9971 \text{ in}^4$ $I_{yy} = 0.8890 \text{ in}^4$ $S_{xx} = 0.8388 \text{ in}^3$ $S_{yy} = 0.7482 \text{ in}^3$ $r_{xx} = 0.9319 \text{ in}$ $r_{yy} = 0.8799 \text{ in}$ $J = 0.986 \text{ in}^4$ $k \leq 1$ for all applications

Allowable bending stress ADM Table 2-21

 $F_{tb} = 19 \text{ ksi}$

$$S_1 = \frac{L_B S_C}{0.5\sqrt{I_y J}} = \frac{L_B \cdot 0.726}{0.5\sqrt{[0.889 \cdot 0.986]}} = 1.551 L_B$$

for $L_B \leq 146 = 94.1'' \rightarrow F_{CB} = 21 \text{ ksi}$

1.551

for $L_B > 94.1'' F_{CB} = 2.39 - 0.24(1.551L_B)^{1/2}$

Strong axis bending (typically perpendicular to rail)

$$M_{all} = 0.8388 \cdot 19^{\text{ksi}} = 15,937 \text{ #''} = 1,328.1' \text{ #}$$

Weak axis bending (typically parallel to rail)

$$M_{all} = 0.7482 \cdot 19^{\text{ksi}} = 14,216 \text{ #''} = 1,184.65' \text{ #}$$

EDWARD C. ROBISON, PE

10012 Creviston Dr NW

Gig Harbor, WA 98329

253-858-0855/Fax 253-858-0856 elrobison@narrows.com

SIX SCREW CONNECTION TO BASE PLATE

Screws are the same as for the standard 4 screw connection.

Screw embedment length into the screw slots is adequate to develop the full screw tension strength.

Use same screw tension strength as used for the four screw connection:

$$T_a = 2,293\# \text{ per screw}$$

$$V_a = 917\# \text{ per screw}$$

$$V_{des} = 6 * 917 = 5,502\#$$

limiting shear load on post so that screw shear stress doesn't reduce the allowable tension:

$$V_{0.2} = 0.2 * 5,502\# = 1,100\#$$

Base plate thickness and strength same as for standard post.

Allowable moment on the posts based on screw tension strength:

Strong axis bending -

$$M_{base} = 3 \text{ screws} * 2,293\# * 2.28'' = 15,684''\# < 15,937''\#$$

Doesn't develop full post strength.

Weak axis bending -

$$M_{base} = 2 \text{ screws} * 2,293\# * 2.28'' + 2 \text{ screws} * 0.5 * 2,293\# * 2.28'' / 2 = 13,070''\# \leq 14,216''\#$$

6 screw connection won't develop the full post strength for weak axis bending.

LIMITING POST MOMENTS FOR SIX SCREW CONNECTION:

$$\text{STRONG AXIS BENDING } M_A = 15,684''\# = 1,307'\#$$

$$\text{WEAK AXIS BENDING } M_A = 13,070''\# = 1,089'\#$$

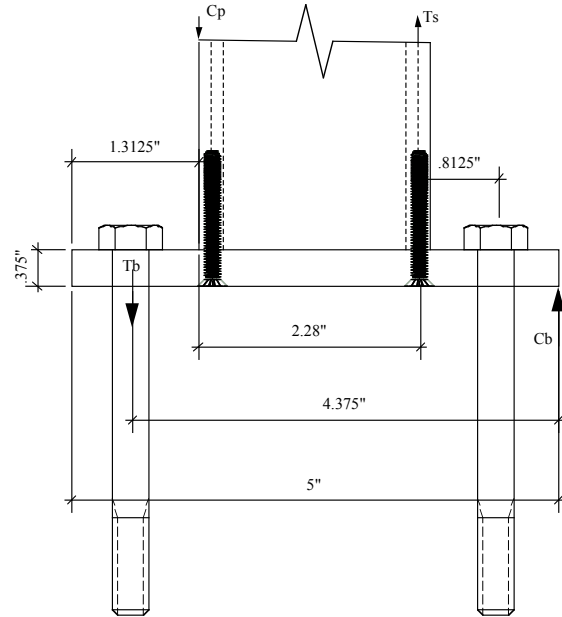

EDWARD C. ROBISON, PE

10012 Creviston Dr NW

Gig Harbor, WA 98329

253-858-0855/Fax 253-858-0856 elrobison@narrows.com

FASCIA BRACKET

Allowable stresses

ADM Table 2-24 6063-T6 Aluminum

$F_t = 15$ ksi, uniform tension

$F_t = 20$ ksi, flat element bending

$F_B = 31$ ksi

$F_c = 20$ ksi, flat element bending

Section Properties

Area: 2.78 sq in

Perim: 28.99 in

$I_{xx} = 3.913$ in⁴

$I_{yy} = 5.453$ in⁴

$C_{xx} = 1.975$ in/1.353 in

$C_{yy} = 2.954$ in

$S_{xx} = 1.981$ in³ front

$S_{xx} = 2.892$ in³

$S_{yy} = 1.846$ in³

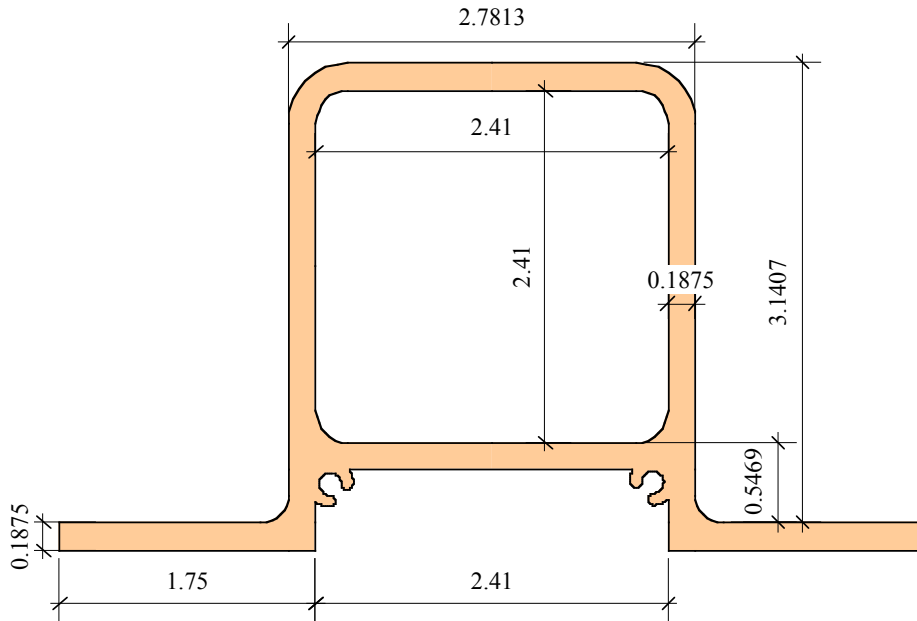
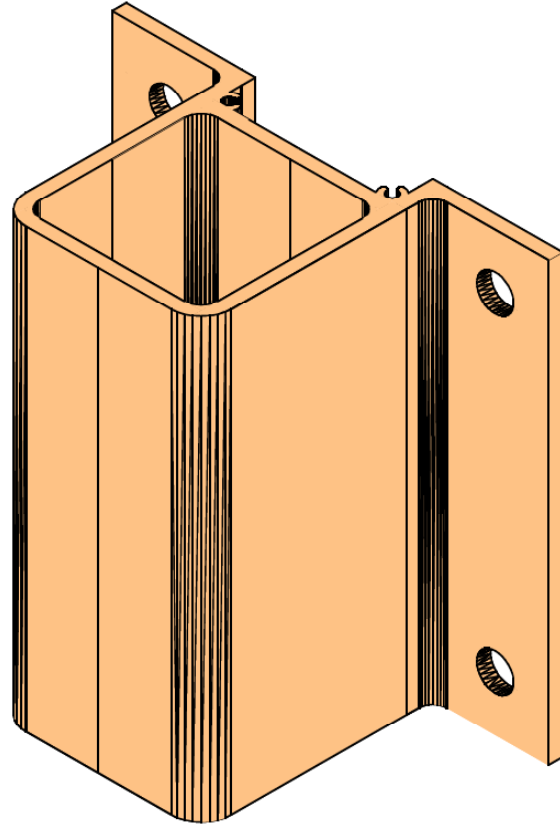

EDWARD C. ROBISON, PE

10012 Creviston Dr NW

Gig Harbor, WA 98329

253-858-0855/Fax 253-858-0856 elrobison@narrows.com

Allowable moment on bracket:

$$M_a = F_t * S$$

$$M_{axx} = 15 \text{ ksi} * 1.981 \text{ in}^3 = 29,175 \text{''#} - \text{Outward moment}$$

$$M_{ayy} = 15 \text{ ksi} * 1.846 \text{ in}^3 = 27,690 \text{''#} - \text{Sidewise moment}$$

Flange bending strength

Determine maximum allowable bolt load:

Tributary flange

$$b_f = 8t = 8 * 0.1875 = 1.5'' \text{ each side of hole}$$

$$b_t = 1.5'' + 1'' + 0.5'' + 1.75'' = 4.75''$$

$$S = 4.75'' * 0.1875^2 / 6 = 0.0278 \text{ in}^3$$

$$M_{af} = 0.0278 \text{ in}^3 * 20 \text{ ksi} = 557 \text{''#}$$

Allowable bolt tension

$$T = M_{af} / 0.375 = 1,485 \text{#}$$

3/8'' bolt standard washer

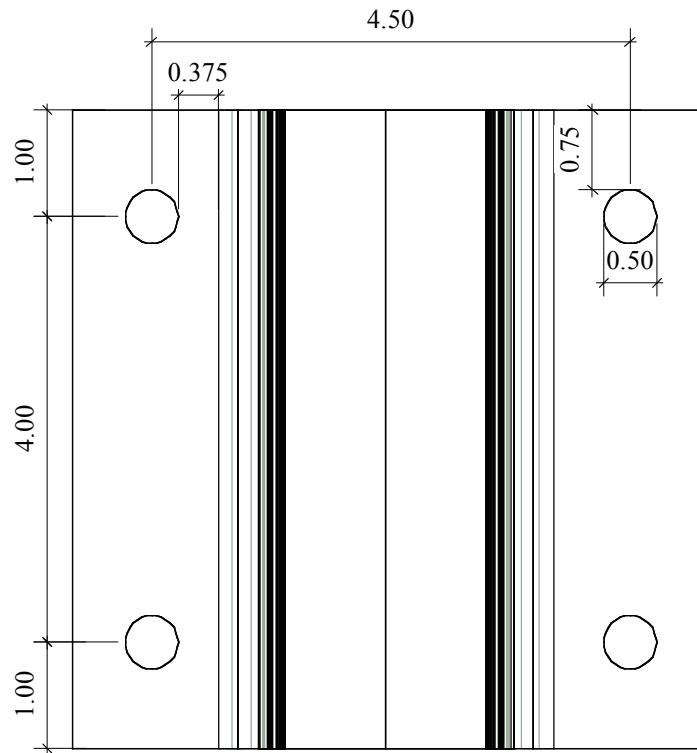

For Heavy washer

$$T = M_{af} / 0.1875 = 2,971 \text{#}$$

Typical Installation – Post load = 250# at 42'' AFF – Top hole is 3'' below finish floor

$$T_{up} = [250 \text{#} * (42'' + 7'') / 5''] / 2 \text{ bolts} = 1,225 \text{# tension}$$

$$T_{bot} = [250 \text{#} * (42'' + 3'') / 5''] / 2 \text{ bolts} = 1,125 \text{# tension}$$

For centerline holes:

$$T = [250 \text{#} * (42'' + 5'') / 3''] / 2 \text{ bolts} = 1,958 \text{# tension}$$

For lag screws into beam face:

- 3/8'' lag screw – withdrawal strength per NDS Table 11.2A

$$\text{Wood species} - G \geq 0.43 - W = 243 \text{#/in}$$

$$\text{Adjustments} - C_d = 1.33, C_m = 0.75 \text{ (where weather exposed)}$$

No other adjustments required.

$$W' = 243 \text{#/in} * 1.33 = 323 \text{#/in} - \text{where protected from weather}$$

$$W' = 243 \text{#/in} * 1.33 * 0.75 = 243 \text{#/in} - \text{where weather exposed}$$

For protected installations the minimum embedment is:

$$l_e = 1,225 \text{#} / 323 \text{#/in} = 3.79'' : +7/32'' \text{ for tip} = 4.0''$$

For weather exposed installations the minimum embedment is:

$$l_e = 1,225 \text{#} / 243 \text{#/in} = 5.04'' : +7/32'' \text{ for tip} = 5.26'' \text{ requires } 5\text{-}1/2'' \text{ screw}$$

EDWARD C. ROBISON, PE

10012 Creviston Dr NW

Gig Harbor, WA 98329

253-858-0855/Fax 253-858-0856 elrobison@narrows.com

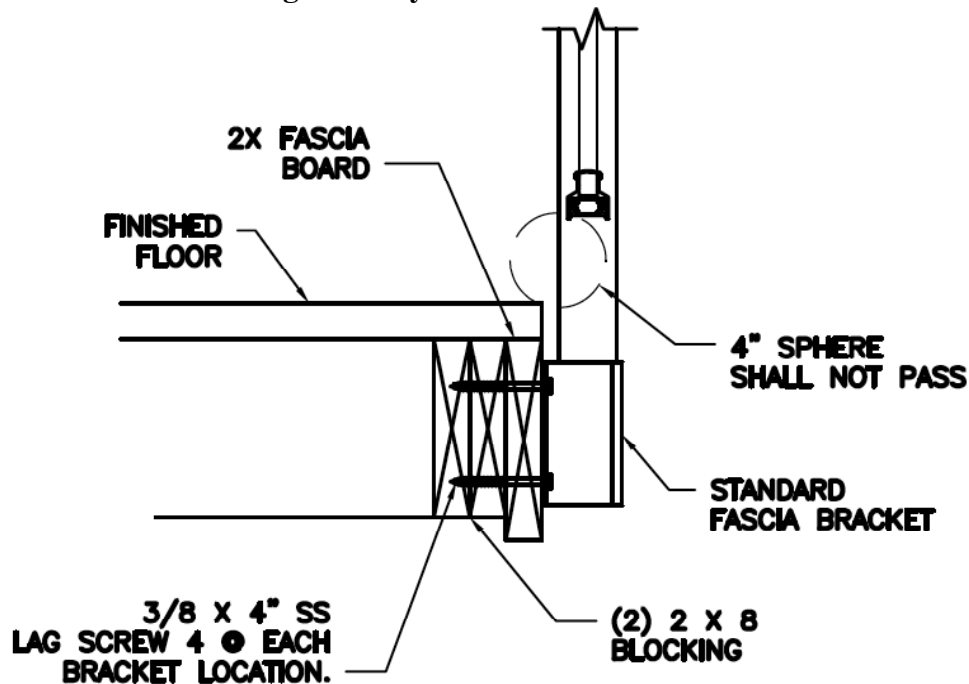
Fascia Brackets- Single Family Residence installations to wood deck:

Typical Installation – Post load = 200# at 36” AFF – Top hole is 3” below finish floor

$$T_{up} = [200\# \cdot (36'' + 7'') / 5''] / 2 \text{ bolts} = 860\# \text{ tension}$$

$$T_{bot} = [200\# \cdot (36'' + 3'') / 5''] / 2 \text{ bolts} = 780\# \text{ tension}$$

For protected installations the minimum embedment is:

$$l_e = 860\# / 323\# / \text{in} = 2.66'' : +7/32'' \text{ for tip} = 2.88''$$

For weather exposed installations the minimum embedment is:

$$l_e = 860\# / 243\# / \text{in} = 3.54'' : +7/32'' \text{ for tip} = 3.76''$$

4” lag screws are acceptable for installation with 36” guard height on residential decks.

Backing may be either built-up 2x lumber or solid beams.

Typical Installation – Post load = 200# at 42” AFF – Top hole is 3” below finish floor

$$T_{up} = [200\# \cdot (42'' + 7'') / 5''] / 2 \text{ bolts} = 980\# \text{ tension}$$

$$T_{bot} = [200\# \cdot (42'' + 3'') / 5''] / 2 \text{ bolts} = 900\# \text{ tension}$$

For protected installations the minimum embedment is:

$$l_e = 980\# / 323\# / \text{in} = 3.03'' : +7/32'' \text{ for tip} = 3.25''$$

For weather exposed installations the minimum embedment is:

$$l_e = 980\# / 243\# / \text{in} = 4.03'' : +7/32'' \text{ for tip} = 4.25''$$

5” lag screws are required for installation with 42” guard height on residential decks.

Backing may be either built-up 2x lumber or solid beams.

EDWARD C. ROBISON, PE

10012 Creviston Dr NW

Gig Harbor, WA 98329

253-858-0855/Fax 253-858-0856 elrobison@narrows.com

FASCIA MOUNTED POST

Commercial application – Load = 200# or 50 plf any direction on top rail

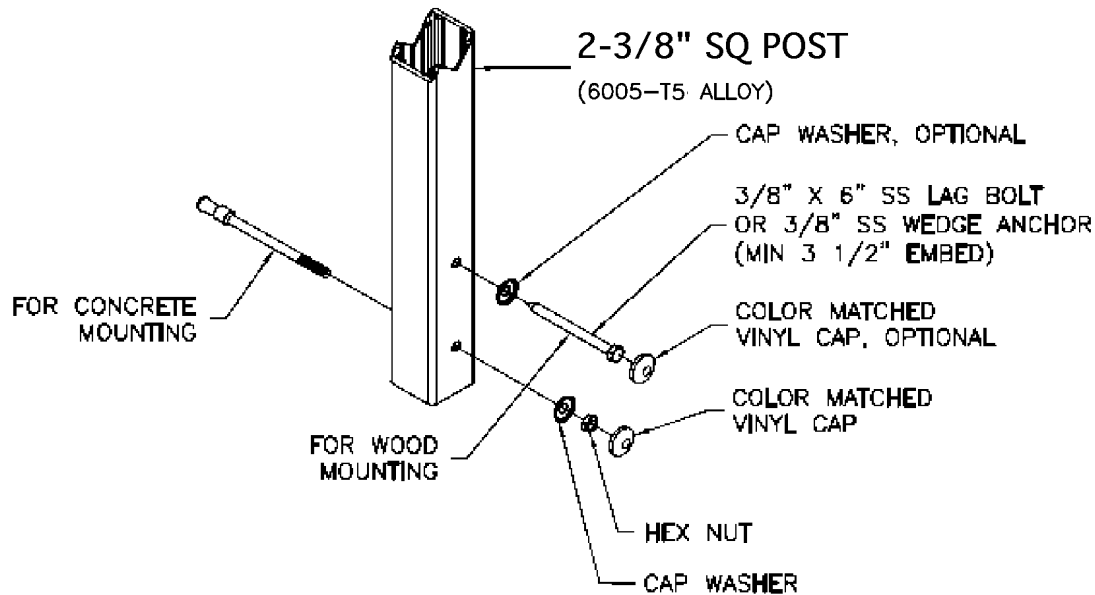

For 42" rail height and 4' on center post spacing:

$$P = 200\# \text{ or } 50\text{plf} \times 4 = 200\#$$

$$M_{\text{deck}} = 42'' \times 200\text{plf} = 8,400''\#$$

Load from glass infill lites:

$$\text{Wind} = 25 \text{ psf}$$

$$M_{\text{deck}} = 3.5' \times 25\text{psf} \times 42'' / 2 \times 4' \text{ o.c.} = 7,350''\#$$

$$DL = 4' \times (3 \text{ psf} \times 3' + 3.5\text{plf}) + 10\# = 60\# \text{ each post (vertical load)}$$

Typical anchor to wood: 3/8" lag screw. Withdrawal strength of the lags from *National Design Specification For Wood Construction* (NDS) Table 11.2A.

For Doug-Fir Larch or equal, $G = 0.50$

$$W = 305 \#/\text{in of thread penetration.}$$

$$C_D = 1.33 \text{ for guardrail live loads, } = 1.6 \text{ for wind loads.}$$

$$C_m = 1.0 \text{ for weather protected supports (lags into wood not subjected to wetting).}$$

$$T_b = W C_D C_m l_m = \text{total withdrawal load in lbs per lag}$$

$$W' = W C_D C_m = 305\#/\text{in} \times 1.33 \times 1.0 = 405\#/\text{in}$$

Lag screw design strength – 3/8" x 5" lag, $l_m = 5'' - 2.375'' - 7/32'' = 2.4''$

$$T_b = 405 \times 2.4'' = 972\#$$

$$Z_{II} = 220\# \text{ per lag, (horizontal load) NDS Table 11K}$$

$$Z'_{II} = 220\# \times 1.33 \times 1.0 = 295\#$$

$$Z_T = 140\# \text{ per lag, (vertical load)}$$

$$Z_T = 140\# \times 1.33 \times 1.0 = 187\#$$

EDWARD C. ROBISON, PE

10012 Creviston Dr NW

Gig Harbor, WA 98329

253-858-0855/Fax 253-858-0856 elrobison@narrows.com

Anchors to be minimum of 7" center to center and post shall extend 1-1/2" below bottom anchor.

From $\sum M$ about end

$$M = (8.5'' * T + 1.5'' * 1.5/8.5 * T) = 8.76'' T$$

Allowable post moment

$$M_a = 972\# * 8.76'' = 8,515''\#$$

For 3/8" lag screw okay for 36" rail height

For 3/8" carriage bolts:

$$\text{Allowable load per bolt} = 0.11 \text{ in}^2 * 20 \text{ ksi} = 2,200\#$$

For bearing on 2" square bearing plate – area = 3.8 in²

$$P_b = 3.8 \text{ in}^2 * 1.19 * 405 * 1.33 = 2,436\#$$

$M_a = 2,200\# * 8.76'' = 19,272''\#$ (exceeds post strength)

For vertical load lag capacity is:

$$2 \text{ lags} * 187\# = 374\#/\text{post for live load}$$

$$2 \text{ lags} * 140\# = 280\#$$

$$D + L = 200/374 + 60/280 = 0.75 < 1.0 \text{ okay}$$

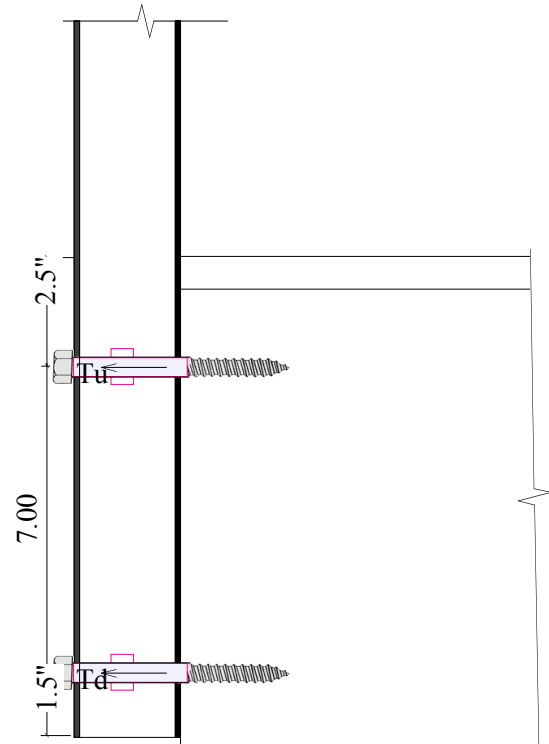

For corner posts:

For interior and exterior corners there is four lags, two each way. Two lags will act in withdrawal and two will be in shear: Okay by inference from running posts.

POST STRENGTH AT BOLT HOLE:

Directly mounted posts require 7/16" diameter hole through post reducing the post strength at the hole.

$$S_h = 0.726 - 2 * (7/16 * 0.125) * (2.255/2)^2 = 0.588 \text{ in}^3$$

$$M_{\text{ared}} = 19,000 * 0.588 = 11,172''\#$$

Maximum moment calculated at the centerline of the top hole must not exceed 11,172''# = 931' #

EDWARD C. ROBISON, PE

10012 Creviston Dr NW

Gig Harbor, WA 98329

253-858-0855/Fax 253-858-0856 elrobison@narrows.com

STANCHION MOUNT

2"x1-1/2"x 1/8" A500 steel tube

Stanchion Strength

$F_{yc} = 45 \text{ ksi}$

$Z_{yy} = 0.543 \text{ in}^3$

$M_n = 0.543 \text{ in}^3 * 45 \text{ ksi} = 24,435\#"$

$M_s = \phi M_n / 1.6 = 0.9 * 24,435 / 1.6 = 13,745\#"$

Equivalent post top load

42" post height

$V = 13,745\# / 42" = 327\#$

Post may be attached to stanchion with screws or by grouting.

Grout bond strength to stanchion:

$A_{\text{surface}} \sqrt{f'_c} = 7" * 4" * \sqrt{8,000 \text{ psi}} = 2,500\#$

(ignores mechanical bond)

for 200# maximum uplift the safety factor against pulling out:

$SF = 2,500\# / 200\# = 12.5 > 3.0$ therefore

okay.

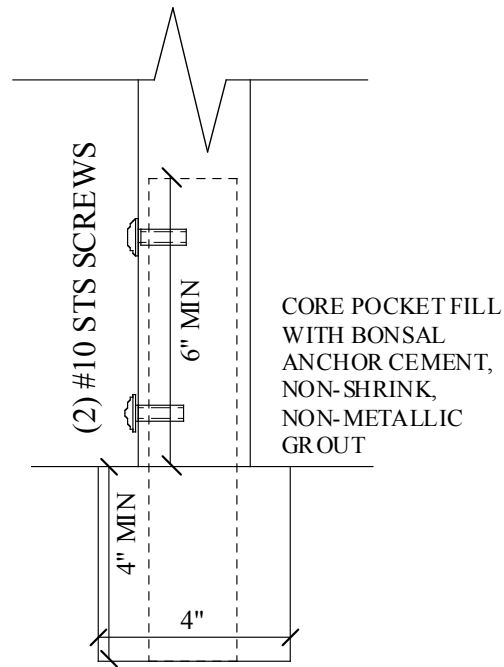

Bearing strength on grout:

From $\sum M$ about base of stanchion = 0

$P_u = \frac{M + V * D}{2/3 D}$

For: $M = 10,500\#"$, $V = 250\text{lb}$, $D = 4"$

$P_u = \frac{10,500 + 250 * 4}{2/3 * 4} = 4,312\#$

$f_{B_{\text{max}}} = \frac{P_u * 2}{D * 1.5 * 0.85} = \frac{4,312 * 2}{4 * 1.5 * 0.85} = 1,691 \text{ psi}$

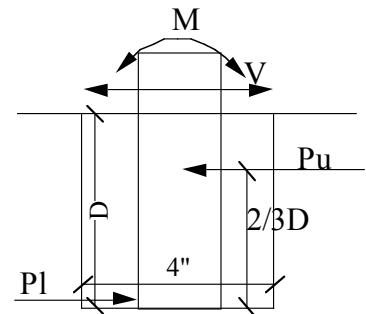

For: $M = 12,600\#"$, $V = 300\text{lb}$, $D = 4"$

$P_u = \frac{12,600 + 300 * 4}{2/3 * 4} = 5,175\#$

$f_{B_{\text{max}}} = \frac{P_u * 2}{D * 1.5 * 0.85} = 2,029 \text{ psi}$

Post bearing load on top of stanchion for $M = 12,600\#"$:

$B = 12,600 / 6" = 2,100\#$

For 26 ksi allowable bearing pressure, $A = 2.1 / 26 = 0.081"$, $b = 0.081 / 1.5" = 0.054"$

EDWARD C. ROBISON, PE

10012 Creviston Dr NW

Gig Harbor, WA 98329

253-858-0855/Fax 253-858-0856 elrobison@narrows.com

HSS 2"x1-1/2"x 1/8" powder coated A500 steel tube stanchion:

Stanchion Strength

$$F_y = 46 \text{ ksi}$$

$$Z_{yy} = 0.475 \text{ in}^3$$

$$M_n = 0.475 \text{ in}^3 * 46 \text{ ksi} = 21,850\#"$$

$$M_s = \phi M_n / 1.6 = 0.9 * 21,850 / 1.6 = 12,291\#"$$

Equivalent post top load

42" post height

$$V = 12,291\# / 42" = 293\#$$

May be welded to a steel base plate with fillet weld all around.

Aluminum Tube Stanchion

2" x 1.5" x 1/4" 6061-T6 Aluminum Tube

$$F_{cb} = 21 \text{ ksi} \quad \text{From ADM Table 2-22}$$

$$S_{yy} = 0.719 \text{ in}^3$$

$$M_a = 0.719 \text{ in}^3 * 21 \text{ ksi} = 15,099\#"$$

Equivalent post top load

42" post height

$$V = 15,099\# / 42" = 360\#$$

Strength of weld affected aluminum stanchion when welded to base plate:

$$F_{cbw} = 9 \text{ ksi}$$

$$S_{yy} = 0.719 \text{ in}^3$$

$$M_a = 0.719 \text{ in}^3 * 9 \text{ ksi} = 6,471\#"$$

Equivalent post top load

42" post height

$$V = 6,471\# / 42" = 154\#$$

Because of strength reduction from weld effected metal the aluminum stanchion welded to a base plate typically requires a topping slab to be poured in place over the base plate with a minimum thickness of 2" above the base plate so that the maximum bending moment occurs outside of the weld effected zone.

When welded to base plate limit the maximum moment on the weld effected zone to 6,471" #.

EDWARD C. ROBISON, PE

10012 Creviston Dr NW

Gig Harbor, WA 98329

253-858-0855/Fax 253-858-0856 elrobison@narrows.com

STANCHION MOUNT – ON BASE PLATE

2"x1-1/2"x 1/8" A304 1/4 hard Stainless steel tube
or A500 steel tube powder coated

Stanchion Strength

$$F_{yc} = 50 \text{ ksi}$$

$$Z_{yy} = 0.543 \text{ in}^3$$

Reserve strength method from SEI ASCE8-02 section
3.3.1.1 procedure II.

$$\text{where } d_c/t = (2 \cdot 2/3) / 0.125 = 10.67 < \lambda_1$$

$$\lambda_1 = 1.1 / \sqrt{(F_{yc} / E_o)} = 1.1 / \sqrt{(50 / 28 \cdot 10^3)} = 26$$

$$M_n = 0.543 \text{ in}^3 \cdot 50 \text{ ksi} = 27,148 \#"$$

$$M_s = \phi M_n / 1.6 = 0.9 \cdot 27,148 / 1.6 = 15,270 \#"$$

Equivalent post top load

42" post height

$$V = 15,270 \# / 42" = 363 \#$$

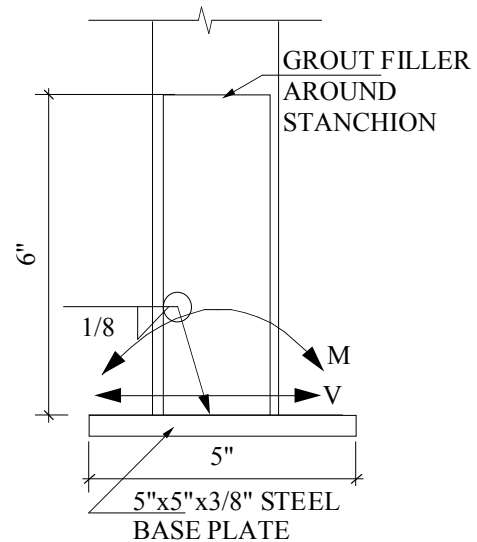

Weld to base plate : 1/8" fillet weld all around – develops full wall thickness.

Check weld strength SEI/ASCE 8-02 section 5.2.2: transverse loaded fillet weld:

$$\phi P_n = \phi t L F_{ua}, \text{ Use Z for } tL$$

$$P_n = 0.55 \cdot 0.362 \cdot 80 \text{ ksi}$$

$$P_n = 15,928$$

$$P_s = 15,928 / 1.2 = 13,273 \#"$$

Grout bond strength to stanchion:

$$A_{\text{surface}} \sqrt{f'_c} = 7" \cdot 6" \cdot \sqrt{10,000 \text{ psi}} = 4,200 \# \text{ (ignores mechanical bond)}$$

for 200# maximum uplift the safety factor against pulling out:

$$SF = 4,200 \# / 200 \# = 21 > 3.0 \text{ therefore okay.}$$

Bond strength to post is similar.

EDWARD C. ROBISON, PE

10012 Creviston Dr NW

Gig Harbor, WA 98329

253-858-0855/Fax 253-858-0856 elrobison@narrows.com

Series 100 Top Rail

Butts into post

Alloy 6063 – T6 Aluminum

Allowable Stress

ADM Table 2-24

 $F_T = 15$ ksi $F_C \rightarrow 6'$ span

$$\frac{2 L_b S_C}{(I_y J)} = \frac{2 \cdot 72'' \cdot 0.246}{(0.295 \cdot 1.53)^{1/2}}$$

$$= 52.7 < 130 \text{ therefore}$$

$$F_c = 15 \text{ ksi}$$

Allowable Moments \rightarrow

$$\text{Horiz.} = 0.295 \text{ in}^3 \cdot 15 \text{ ksi} = 4,425 \text{ #''} = 368.75 \text{ #'}$$

$$\text{Vertical load} = 0.246 \text{ in}^3 \cdot 15 \text{ ksi} = 3,690 \text{ #''} = 307.5 \text{ #'}$$

Maximum allowable load for 72'' o.c. post spacing - vertical

$$W = 3,690 \text{ #''} \cdot 8 / (69.625 \text{''}^2) = 6.09 \text{ pli} = 73.1 \text{ plf}$$

$$P = 3,690 \text{ #''} \cdot 4 / 69.625 \text{''} = 212 \text{ #}$$

Maximum span without load sharing, $P = 200 \text{ #}$ - vertical

$$S = 3,690 \text{ #''} \cdot 4 / 200 \text{ #} = 73.8 \text{'' clear}$$

$$\text{Max post spacing} = 73.8 \text{''} + 2.375 \text{''} = 76.175 \text{''}$$

For horizontal loading rail strength is greater and therefore okay by inference.

Maximum allowable load for 72'' length horizontal load

$$W = 4,425 \text{ #''} \cdot 8 / 72^2 = 6.8 \text{ pli} = 81.9 \text{ plf}$$

$$P = 4,425 \text{ #''} \cdot 4 / 72 \text{''} = 245.8 \text{ #}$$

Maximum span for $P = 200 \text{ #}$ and $W = 50 \text{ plf}$ horizontal load

$$W = \sqrt{(368.75 \text{ #''} \cdot 8 / 50)} = 7.68' = 7' 8.5 \text{''}$$

$$P = 368.75 \text{ #''} \cdot 4 / 200 = 7.375' = 7' 3.5 \text{'' controls}$$

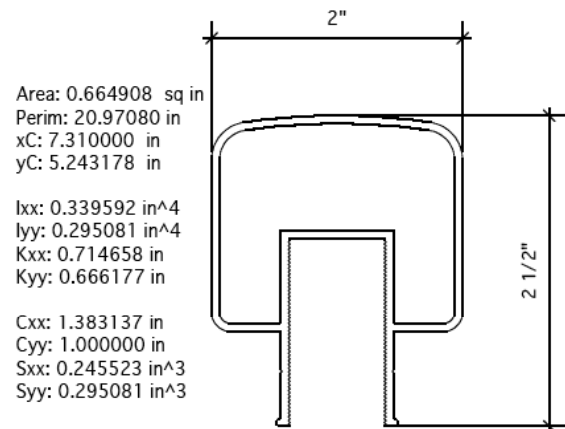
SERIES 100 TOP RAIL

EDWARD C. ROBISON, PE

10012 Creviston Dr NW

Gig Harbor, WA 98329

253-858-0855/Fax 253-858-0856 elrobison@narrows.com

SERIES 100 BOTTOM RAIL

Rail Properties:

6063-T6 Aluminum

$$I_{xx} = 0.102 \text{ in}^4, \quad S_{xx} = 0.101 \text{ in}^3$$

$$I_{yy} = 0.164 \text{ in}^4, \quad S_{yy} = 0.193 \text{ in}^3$$

$$r_{xx} = 0.476", \quad r_{yy} = 0.603"$$

For 72" on center posts; $L = 72" - 2.375" - 1" \times 2 = 67.625"$; $L_b = 1/2L = 33.81"$

$$L_b/r_y = 33.81"/0.603 = 56 \text{ From ADM Table 2-24}$$

$$F_{bc} = 16.7 - 0.073 \cdot 56 = 12.6 \text{ ksi}$$

Allowable Moments \rightarrow Horiz. = $0.193 \text{ in}^3 \cdot 12.6 \text{ ksi} = 2,432"$ #

Maximum allowable load for 72" o.c. post spacing

$$W = 2,432" \cdot 8 / (67.625")^2 = 4.25 \text{ pli} = 51 \text{ plf}$$

$$P = 2,432" \cdot 4 / 67.625" = 144\#$$

Max span for 50 plf load = $(8 \cdot 2,432 / (50/12))^{1/2} = 68.33"$ clear span

Rail fasteners -Bottom rail connection block to post #10x1.5" 55 PHP SMS Screw

Check shear @ post (6005-T5 or 6061-T6)

$2 \times F_{upost} \times \text{dia screw} \times \text{Post thickness} \times \text{SF}$

$$V = 2 \cdot 38 \text{ ksi} \cdot 0.1697" \cdot 0.10" \cdot \frac{1}{3} \text{ (FS)} =$$

$$V = 430\#/\text{screw}$$

Since minimum of 2 screws used for each

$$\text{Allowable load} = 2 \cdot 430\# = 860\#$$

Rail Connection to RCB

2 screws each end

#8 Tek screw to 6063-T6

$$V = 2 \cdot 30 \text{ ksi} \cdot 0.1309" \cdot 0.07" \cdot \frac{1}{3} \text{ (FS)} = 183\#$$

$$V_{All} = 2 \cdot 183 = 366\#$$

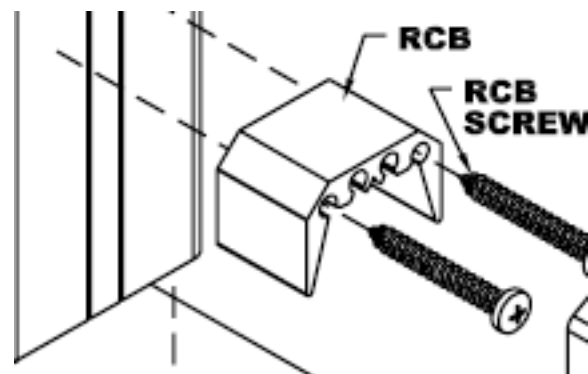
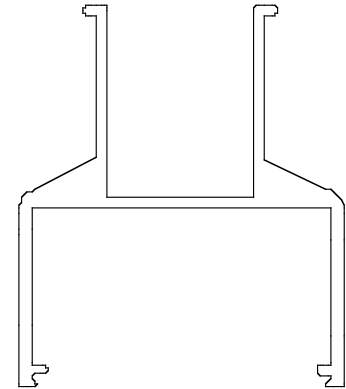

EDWARD C. ROBISON, PE

10012 Creviston Dr NW

Gig Harbor, WA 98329

253-858-0855/Fax 253-858-0856 elrobison@narrows.com

Intermediate post used to provide additional support to bottom rail.

1.4" square 0.1" wall thickness

Acts in compression only.

Secured to rail with two #8 tek screws

Shear strength of screws:

#8 Tek screw to 6063-T6

$$V = 2 \cdot 30 \text{ ksi} \cdot 0.1309'' \cdot 0.07'' \cdot \frac{1}{3} \text{ (FS)} = 183\#$$

$$V_{\text{All}} = 2 \cdot 183 = 366\#$$

Top rail connection to post face:

Use RCB attached to post with 2 #10 screws same as bottom rail.

To 6061-T6 or 6005-T5

$$V = 2 \cdot 38 \text{ ksi} \cdot 0.1697'' \cdot 0.10'' \cdot \frac{1}{3} \text{ (FS)} = 430\#/\text{screw}$$

Since minimum of 2 screws
used for each

Allowable load =

$$2 \cdot 430\# = 860\#$$

The connection block can be
cut square for use in horizontal
rail applications or angled for
use in sloped applications such
as along stairs or ramps.

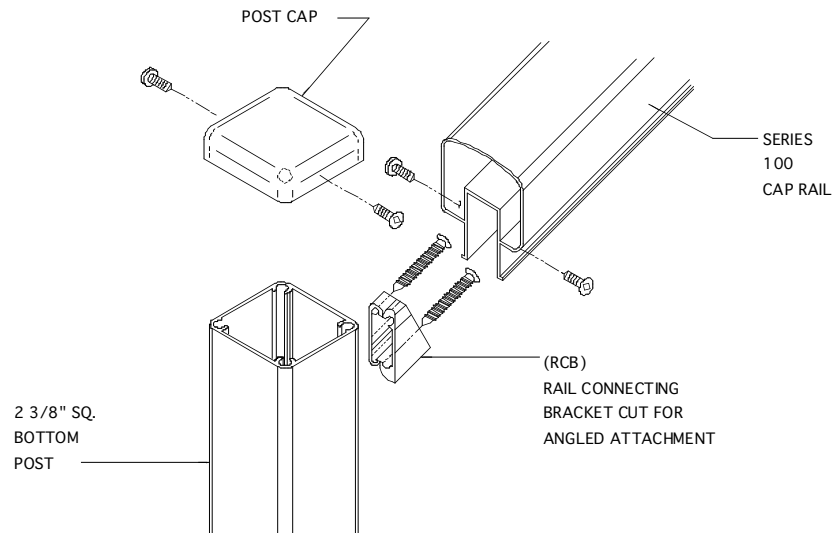

Connection of rail to RCB is
with (2) #8 Tek screw to 6063-T6

$$V = 2 \cdot 30 \text{ ksi} \cdot 0.1309'' \cdot 0.07'' \cdot \frac{1}{3} \text{ (FS)} = 183\#$$

$$V_{\text{tot}} = 2 \cdot 183\# = 366\# \geq 200\# \text{ okay}$$

EDWARD C. ROBISON, PE

10012 Creviston Dr NW

Gig Harbor, WA 98329

253-858-0855/Fax 253-858-0856 elrobison@narrows.com

Intermediate post fitting

Used for intermediate posts along stairways
 Fitting locks into top of post using structural silicone.

Maximum load on fitting is 300#
 6' post spacing * 50 plf = 300#

Shear resisted by direct bearing between fitting and post
 area = 2.175" * 0.1875 = 0.408 in²
 Bearing pressure = 300# / 0.408 = 736 psi

Moment of fitting to post:

This is an intermediate post with rotation of top rail restrained at rail ends.

Moment of fitting is created by eccentricity between bottom of top rail and top of post:

$$e = 0.425''$$

$$M = 300\# * (0.425'') = 127.5\#''$$

Moment on fitting is resisted by tearing in silicone

Silicone tear strength: From Dow Corning, (silicone manufacturer), CRL 95C Silicone is the same product as the Dow Corning 995 Silicone Structural Glazing Sealant, from Dow Corning product information sheet

- Tear strength ≥ 49 ppi
- Peel strength ≥ 40 ppi
- Ult. tension adhesion ≥ 170 psi
- Tensile strength ≥ 48 psi @ 25%

elongation

$$\text{Tensile strength} \geq 75 \text{ psi @ } 50\% \text{ elongation}$$

elongation

Moment capacity:

$$49 * 2.175^2 + (49) / 2 \text{ psi} * 2.175'^2 = 348\#''$$

$$SF = 348\#'' / 127.5\#'' = 2.73 > 2.0 \text{ okay}$$

Option #8 Tek screws:

$$\text{Shear strength} = V = 2.38 \text{ ksi} * 0.1309'' * 0.07'' * \frac{1}{3 \text{ (FS)}} = 232\#$$

$$\text{Added moment capacity} = 232\# * 2.375'' = 551\#''$$

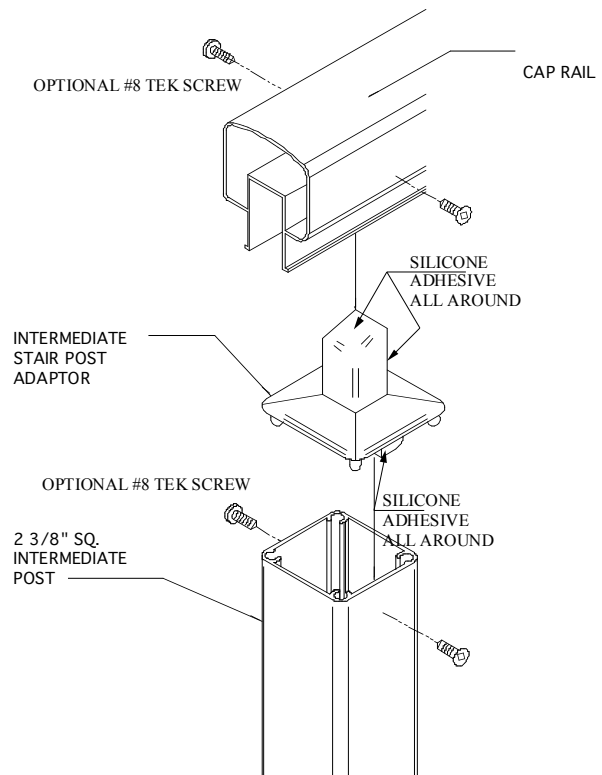

EDWARD C. ROBISON, PE

10012 Creviston Dr NW

Gig Harbor, WA 98329

253-858-0855/Fax 253-858-0856 elrobison@narrows.com

Series 200 Top rail

Area: 0.887 sq in

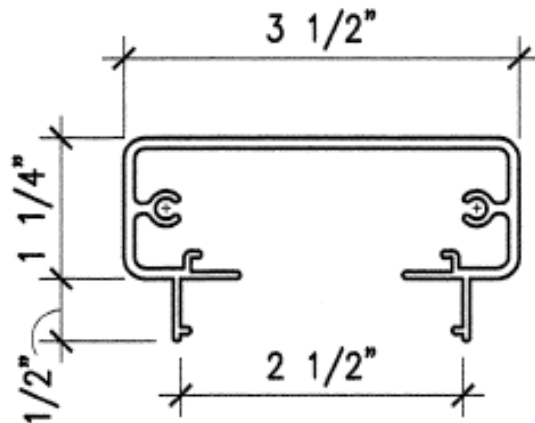
 I_{xx} : 0.254 in⁴ I_{yy} : 1.529 in⁴ r_{xx} : 0.536 in r_{yy} : 1.313 in C_{xx} : 1.194 in C_{yy} : 1.750 in S_{xx} : 0.213 in³ bottom S_{xx} : 0.457 in³ top S_{yy} : 0.874 in³

6063-T6 Aluminum alloy

For 72" on center posts; $L = 72'' - 2.375'' - 1'' \times 2 = 67.625''$; $kL_b = 1/2L = 33.81''$

$$F_{bc} = \frac{16.7 - 0.073 \cdot 33.81}{1.313} = 14.82 \text{ ksi From ADM Table 2-24}$$
 $F_t = 15 \text{ ksi}$ Allowable Moments \rightarrow Horiz. = $0.874 \text{ in}^3 \cdot 14.82 \text{ ksi} = 12,953 \#'' = 1,079 \#'$ Vertical load = $0.457 \text{ in}^3 \cdot 14.82 \text{ ksi} = 6,773 \#''$ top compressionor = $0.213 \text{ in}^3 \cdot 15 \text{ ksi} = 3,195 \#''$ controls vertical- bottom tension

Maximum allowable load for 72" o.c. post spacing - vertical

 $W = 3,195 \#'' \cdot 8 / (67.625''^2) = 5.59 \text{ pli} = 67 \text{ plf}$

$P = 3,195 \#'' \cdot 4 / 67.625'' = 189 \#$ Load sharing with bottom rail required for 6 foot post spacing. Spreader bar at mid span (3' maximum spacing) will subdivide top rail and provide required additional support.

Maximum span without load sharing, $P = 200 \#$ $S = 3,195 \#'' \cdot 4 / 200 \# = 63.9''$ clearMax post spacing = $63.9'' + 2.375'' = 66-1/4''$, 5' 6-1/4"

For horizontal load, maximum span for 50 plf load

 $L = (8Ma/50 \text{ plf})^{1/2} = (8 \cdot 1,079 / 50 \text{ plf})^{1/2} = 13.14'$

for 200# concentrated load

 $L = (4M/200 \#) = (4 \cdot 1,079 / 200 \text{ plf}) = 21.58'$

deflection limits will control.

EDWARD C. ROBISON, PE

10012 Creviston Dr NW

Gig Harbor, WA 98329

253-858-0855/Fax 253-858-0856 elrobison@narrows.com

Series 200X Top rail

Area: 0.744 sq in

Perim: 18.466 in

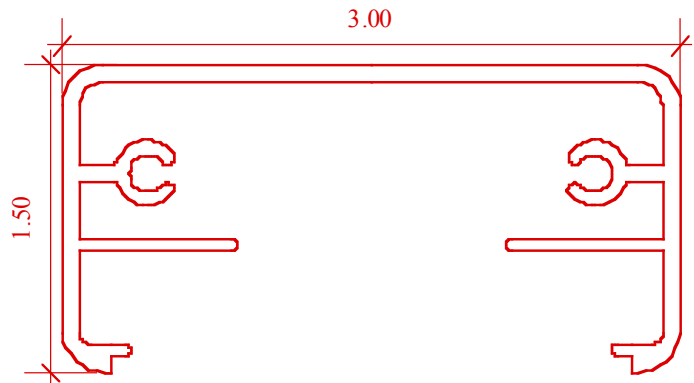
 I_{xx} : 0.154 in⁴ I_{yy} : 1.012 in⁴ r_{xx} : 0.455 in r_{yy} : 1.167 in C_{xx} : 0.960 in C_{yy} : 1.500 in S_{xx} : 0.161 in³ bottom S_{xx} : 0.285 in³ top S_{yy} : 0.675 in³

6063-T6 Aluminum alloy

For 72" on center posts; $L = 72'' - 2.375'' - 1'' \times 2 = 67.625''$; $kL_b = 1/2L = 33.81''$

$$F_{bc} = 16.7 - 0.073 \cdot \frac{33.81}{1.167} = 14.59 \text{ ksi}$$
 From ADM Table 2-24
 $F_t = 15 \text{ ksi}$ Allowable Moments \rightarrow Horiz. = $0.675 \text{ in}^3 \cdot 14.59 \text{ ksi} = 9,845''\# = 820.4\#$ Vertical load = $0.285 \text{ in}^3 \cdot 14.59 \text{ ksi} = 4,158''\#$ or $= 0.161 \text{ in}^3 \cdot 15 \text{ ksi} = 2,415''\#$ controls vertical- bottom tension

Maximum allowable load for 72" o.c. post spacing - vertical

 $W = 2,415''\# \cdot 8 / (67.625''^2) = 4.22 \text{ pli} = 50.7 \text{ plf}$ $P = 2,415''\# \cdot 4 / 67.625'' = 143\#$ Load sharing with bottom rail required for 6 foot post spacing. $P_{\text{total}} = P_{\text{top}} + P_{\text{bottom}} = 143\# + 174\# = 317\# > 200\#$ okay.Maximum span without load sharing single span, $P = 200\#$ $S = 2415''\# \cdot 4 / 200\# = 48.3''$ clearMax post spacing = $48.3'' + 2.375'' = 50.675''$ Maximum span without load sharing and multiple spans, 3 minimum, $P = 200\#$ $S = 2,415''\# \cdot 5 / 200\# = 60 \text{ } 3/8''$ clear

For uniform load = 50 plf:

 $S = \sqrt{[(8 \cdot 2,415''\# / 12) / 50 \text{ plf}]} = 5.67'$ Max post spacing = $30 \text{ } 3/8'' + 2.375'' = 62 \text{ } 3/4''$

For horizontal load, maximum span for 50 plf load

 $L = (8M_a / 50 \text{ plf})^{1/2} = (8 \cdot 820.4 / 50 \text{ plf})^{1/2} = 11.45'$

EDWARD C. ROBISON, PE

10012 Creviston Dr NW

Gig Harbor, WA 98329

253-858-0855/Fax 253-858-0856 elrobison@narrows.com

Top rail 300

Area: 0.881 sq in
 Perim: 21.29 in
 Ixx: 0.603 in⁴
 Iyy: 1.149 in⁴
 Kxx: 0.828 in
 Kyy: 1.142 in
 Cxx: 1.599 in
 Cyy: 1.501 in
 Sxx: 0.377 in³
 Syy: 0.766 in³

Allowable stresses 6063-T6 ADM Table 2-24

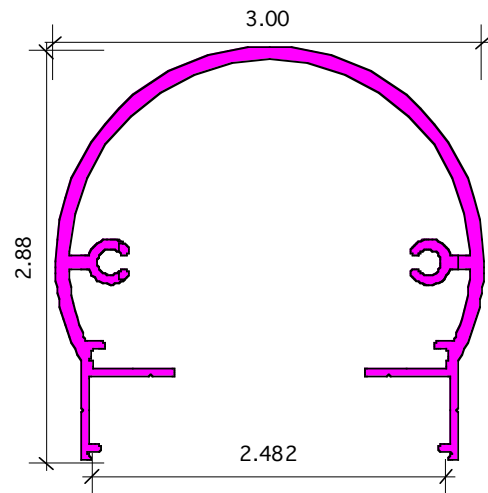

$F_{Cb} \rightarrow (R_b/t) = (1.5''/0.09'') = 16.67 < 35$; $F_{Cb} = 18\text{ksi}$
 Based on 72'' max post spacing

$$M_{\text{all horiz}} = 18\text{ksi} \cdot (0.766) = 13,788''\#$$

Vertical loads shared with bottom rail

For vertical load \rightarrow bottom in tension top comp.

$$F_b = 18 \text{ ksi}$$

$$M_{\text{all vert}} = (0.377\text{in}^4) \cdot 18 \text{ ksi} = 6,786''\#$$

Allowable loads

$$\text{Horizontal} \rightarrow \text{uniform} \rightarrow W = \frac{13,788 \cdot 8}{72^2} = 21.28 \text{ \#/in} = W = 255 \text{ plf}$$

$$P_H = \frac{4 \cdot 13,788}{72} = 766 \text{ \#}$$

$$\text{Vertical} \rightarrow W = \frac{6,786 \cdot 8}{72^2} = 10.47 \text{ \#/in} = 125.7 \text{ plf (Top rail alone)}$$

$$P = \frac{6,786 \cdot 4}{72} = 377 \text{ \#}$$

Rail to post connection: Direct bearing for downward forces and horizontal forces:

For uplift connected by (2) #10 Tek screws each post:

$2 \times F_{\text{upost}} \times \text{dia screw} \times \text{Post thickness} / \text{SF}$ (ADM 5.4.3)

$$V = 2 \cdot 30 \text{ ksi} \cdot 0.1379'' \cdot 0.09'' \cdot \frac{1}{3 \text{ (FS)}} = 325 \text{ \#/screw}$$

EDWARD C. ROBISON, PE

10012 Creviston Dr NW

Gig Harbor, WA 98329

253-858-0855/Fax 253-858-0856 elrobison@narrows.com

Top rail 300X

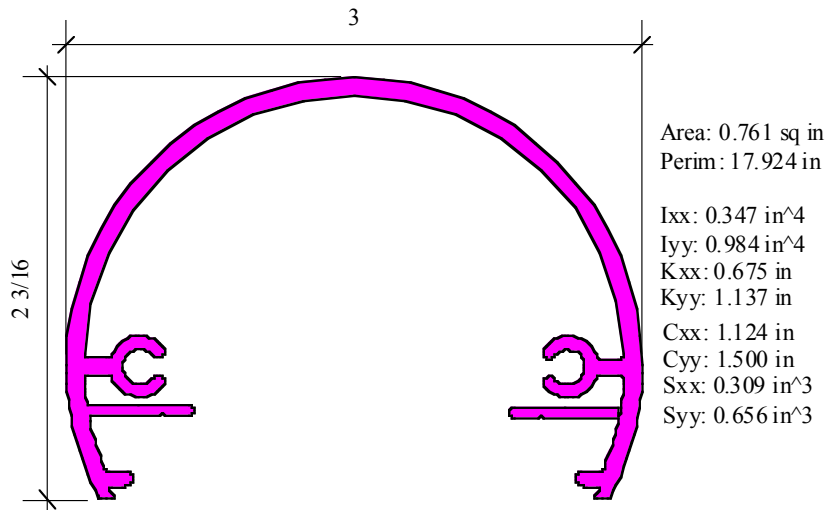

Wall thickness $t = 0.09375''$ min.

Allowable stresses ADM Table 2-24

$$F_{Cb} \rightarrow L/ r_y = \frac{(72 - 2 \frac{3}{8}'' - 2.1'')}{1.137} = 59.4 \text{ line 11}$$

Based on 72'' max post spacing

$$F_{Cb} = 16.7 - 0.073(59.4) = 12.36 \text{ ksi}$$

$$M_{\text{all horiz}} = 12.36^{\text{ksi}} \cdot (0.656) = 8,111''\#$$

Vertical loads shared with bottom rail

For vertical load \rightarrow bottom in tension top comp.

$$F_b = 18 \text{ ksi line 3}$$

$$F_c = 18 \text{ ksi line 16.1}$$

$$M_{\text{all vert}} = (0.309\text{in}^4) \cdot 18 \text{ ksi} = 5,562''\#$$

Allowable loads

$$\text{Horizontal} \rightarrow \text{uniform} \rightarrow W = \frac{8,111 \cdot 8}{72^2} = 12.5 \text{ \#/in} = W = 150 \text{ plf}$$

$$P_H = \frac{4 \cdot 8,111}{72} = 451 \text{ \#}$$

$$\text{Vertical} \rightarrow W = \frac{5,562 \cdot 8}{72^2} = 5.6 \text{ \#/in} = 103 \text{ plf (Top rail alone)}$$

$$P = \frac{5,562 \cdot 4}{72} = 309 \text{ \#}$$

EDWARD C. ROBISON, PE

10012 Creviston Dr NW

Gig Harbor, WA 98329

253-858-0855/Fax 253-858-0856 elrobison@narrows.com

Insert channel for glass – 6063-T6

$$I_{yy} = 0.156 \text{ in}^4 \quad I_{xx} = 0.023 \text{ in}^4$$

$$S_{yy} = 0.125 \text{ in}^3 \quad S_{xx} = 0.049 \text{ in}^4$$

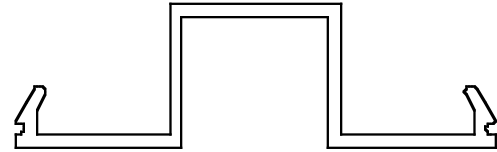

Insert compression locks into top rail

Horizontal forces transferred between insert and top rail by direct bearing on locking tabs.

Bearing area = 1/8" width

Allowable bearing load will be controlled by spreading of top rail

Check significance of circumferential stress:

$$R/t = 3''/0.09375 = 32 > 5 \text{ therefore can assume plane}$$

bending and error will be minimal

$$M = 2.08'' * W$$

$$M_{all} = S * F_b$$

$$F_b = 20 \text{ ksi for flat element bending in own plane,}$$

ADM Table 2-24

$$S = 12''/\text{ft} * (0.094)^2/6 = 0.0177 \text{ in}^3$$

$$W_{all} = M_{all}/2.08'' = (S * F_b)/2.08'' = (0.0177 \text{ in}^3 * 20 \text{ ksi})/2.08'' = 170 \text{ plf}$$

For 36" panel height – 1/2 will be tributary to top rail:

$$\text{Maximum live load} = 170 \text{ plf}/(3'/2) = 113 \text{ psf.}$$

Check deflection:

$$\Delta = WL^3/(3EI)$$

$$I = 12'' * 0.09375^3/12 = .000824 \text{ in}^4$$

$$\Delta = 170 \text{ plf} * 2.08''^3 / (3 * 10.1 \times 10^6 * .000824) = 0.06''$$

The required deflection to cause the infill to disengage: 0.05"

Reduce allowable load to limit total deflection:

$$0.05/0.06 * 113 \text{ plf} = 94 \text{ plf}$$

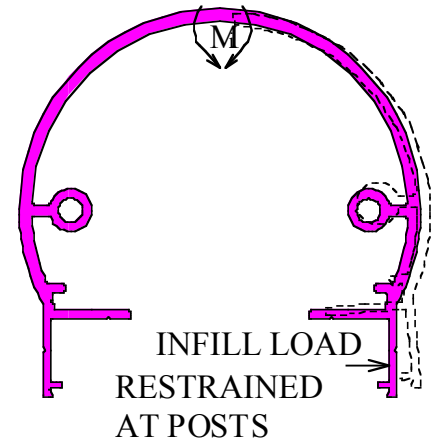

EDWARD C. ROBISON, PE

10012 Creviston Dr NW

Gig Harbor, WA 98329

253-858-0855/Fax 253-858-0856 elrobison@narrows.com

Top rail connection to post:

For Vertical loads top rail is restrained by (2) #10 tek screws each side.
 Connection of bracket to post is with (2) #14 screws so is stronger.

For horizontal loads the top rail directly bears on side of post.

Tek screw strength: Check shear @ rail (6063-T6)

$$2 \times F_{urail} \times \text{dia screw} \times \text{Rail thickness} \times SF$$

$$V = 2 \times 30 \text{ ksi} \times 0.1379'' \times 0.09'' \times \underline{1}$$

$$= 325\#/screw$$

3 (FS)

Since minimum of 2 screws used for each
 Allowable load = 2 * 325# = 650#

Post bearing strength

$$V_{all} = A_{bearing} * F_B$$

$$A_{bearing} = 0.09'' * 2.25'' = 0.2025 \text{ in}^2$$

$$F_B = 21 \text{ ksi}$$

$$V_{all} = 0.2025 \text{ in}^2 * 21 \text{ ksi} = 4.25 \text{ k}$$

Bracket tab bending strength

Vertical uplift force

For 5052-H32 aluminum stamping 1/8" thick

$$F_b = 18 \text{ ksi} - \text{ADM Table 2-09}$$

$$S = 0.438'' * (.125)^3 / 12 = 0.00007 \text{ in}^3$$

$$M_a = 18 \text{ ksi} * 0.00007 = 126''\#$$

$$P_a = M_a / l = 126''\# / 1.158'' = 109\#$$

Uplift limited by bracket strength:

$$Up_{all} = 2 * 109 = 218\# \text{ per bracket}$$

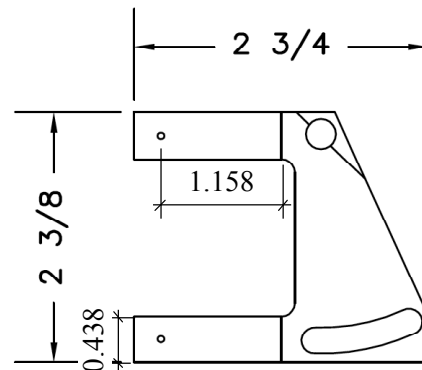
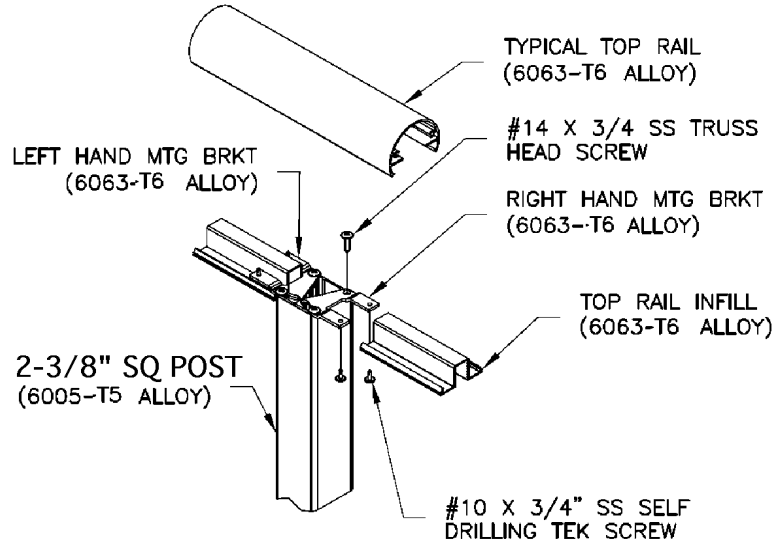

LHB

EDWARD C. ROBISON, PE

10012 Creviston Dr NW

Gig Harbor, WA 98329

253-858-0855/Fax 253-858-0856 elrobison@narrows.com

RAIL SPLICES:

Splice plate strength:

Vertical load will be direct bearing from rail/plate to post no bending or shear in plate.

Horizontal load will be transferred by shear in the fasteners.

Rail to splice plates:

#8 Tek screw strength: Check shear @ rail (6063-T6)

$2 \times F_{urail} \times \text{dia screw} \times \text{rail thickness} \times \text{SF}$

$$V = 2 \cdot 30 \text{ ksi} \cdot 0.1379'' \cdot 0.09'' \cdot \frac{1}{3} (\text{FS}) = 325\#/\text{screw}; \text{ for two screws} = 650\#$$

or $F_{urplate} \times \text{dia screw} \times \text{plate thickness} \times \text{SF}$

$$V = 38 \text{ ksi} \cdot 0.1379'' \cdot 0.125'' \cdot \frac{1}{3} (\text{FS}) = 218\#/\text{screw}; \text{ for two screws} = 436\#$$

Post to splice plate:

Screws into post screw chase so screw to post connection will not control.

splice plate screw shear strength

$2 \times F_{uplate} \times \text{dia screw} \times \text{plate thickness} \times \text{SF}$

$$V = 2 \cdot 38 \text{ ksi} \cdot 0.1379'' \cdot 0.125'' \cdot \frac{1}{3} (\text{FS}) = 416\#/\text{screw}; \text{ for two screws} = 832\#$$

Check moment from horizontal load:

$M = P \cdot 0.75''$. For 200# maximum load from a single rail on to splice plates

$$M = 0.75 \cdot 200 = 150\#''$$

$$S = 0.125 \cdot (0.625)^2 / 6 = 0.008 \text{ in}^3$$

$$f_b = 150\#'' / (0.008 \cdot 2) = 9,216 \text{ psi}$$

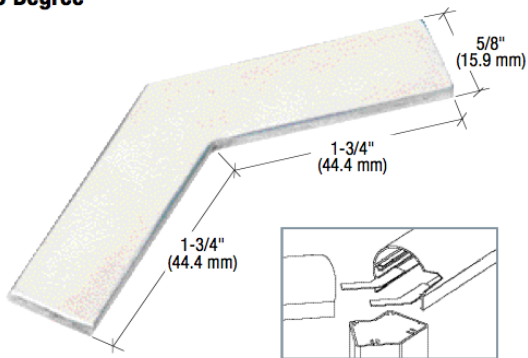
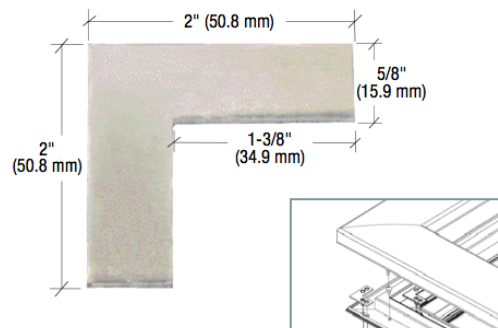
45 Degree**90 Degree**

For corner brackets screw strength and bending strength will be the same.

Single full width bar may be used instead of the two $\frac{5}{8}''$ bars.

May be used to create vertical miters and splice rail sections.

May be used with #10 tek screws.

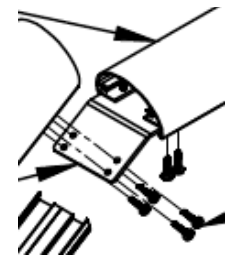

EDWARD C. ROBISON, PE

10012 Creviston Dr NW

Gig Harbor, WA 98329

253-858-0855/Fax 253-858-0856 elrobison@narrows.com

Insert channel for glass – 6063-T6

$$I_{yy} = 0.156 \text{ in}^4 \quad I_{xx} = 0.023 \text{ in}^4$$

$$S_{yy} = 0.125 \text{ in}^3 \quad S_{xx} = 0.049 \text{ in}^3$$

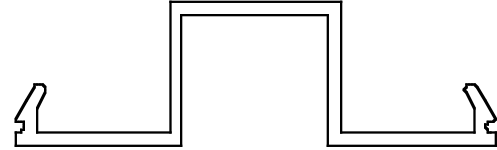

Insert compression locks into top rail

Horizontal forces transferred between insert and top rail by direct bearing on locking tabs.

Bearing area = 1/8" width

Allowable bearing load will be controlled by spreading of top rail

$$M = 2.08'' * W$$

$$M_{all} = S * F_b$$

$F_b = 20 \text{ ksi}$ for flat element bending in own plane, ADM Table 2-24

$$S = 12''/\text{ft} * (0.094)^2/6 = 0.0177 \text{ in}^3$$

$$W_{all} = M_{all}/2.08'' = (S * F_b)/2.08'' = (0.0177 \text{ in}^3 * 20 \text{ ksi})/2.08'' = 170 \text{ plf}$$

For 36" panel height – 1/2 will be tributary to top rail:

$$\text{Maximum wind load} = 170 \text{ plf}/(3'/2) = 113 \text{ psf.}$$

Insert channel for picket infill – 6063-T6

$$I_{yy} = 0.144 \text{ in}^4 \quad I_{xx} = 0.0013 \text{ in}^4$$

$$S_{yy} = 0.115 \text{ in}^3 \quad S_{xx} = 0.0057 \text{ in}^3$$

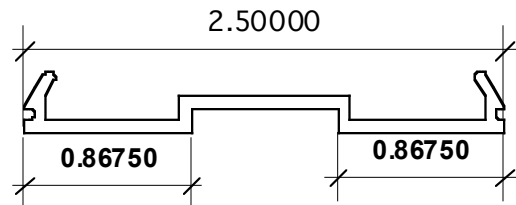

Insert compression locks into top rail

Horizontal forces transferred between insert and top rail by direct bearing on locking tabs.

Bearing area = 1/8" width

Allowable bearing load will be controlled by spreading of top rail

$$M = 2.08'' * W$$

$$M_{all} = S * F_b$$

$F_b = 20 \text{ ksi}$ for flat element bending in own plane, ADM Table 2-24

$$S = 12''/\text{ft} * (0.094)^2/6 = 0.0177 \text{ in}^3$$

$$W_{all} = M_{all}/2.08'' = (S * F_b)/2.08'' = (0.0177 \text{ in}^3 * 20 \text{ ksi})/2.08'' = 170 \text{ plf}$$

For 36" panel height – 1/2 will be tributary to top rail:

$$\text{Maximum live load} = 170 \text{ plf}/(3'/2) = 113 \text{ psf.}$$

EDWARD C. ROBISON, PE

10012 Creviston Dr NW

Gig Harbor, WA 98329

253-858-0855/Fax 253-858-0856 elrobison@narrows.com

Top Rail Series 320

$$I_{xx} = 0.118 \text{ in}^4$$

$$I_{yy} = 0.796 \text{ in}^4$$

$$S_{xx} = 0.129 \text{ in}^3$$

$$S_{yy} = 0.531 \text{ in}^3$$

Allowable stresses ADM Table 2-24

6063-T6 Aluminum

$$F_t = 19 \text{ ksi}$$

$$F_{Cb} \rightarrow R_b/t = \frac{1.5''}{0.1} = 15 \text{ line 16}$$

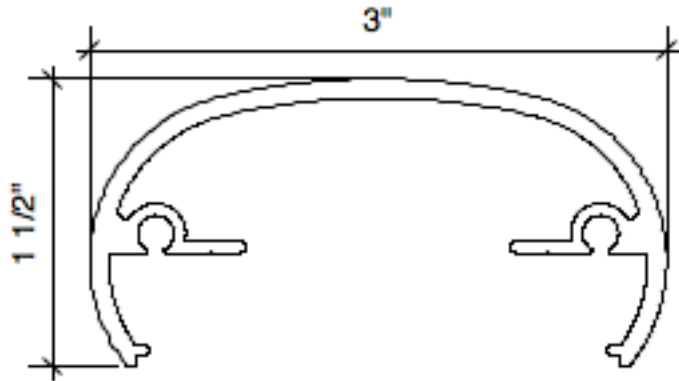

Based on 72" max post spacing

$$F_{Cb} = 21 \text{ ksi}$$

For horizontal loads:

$$M_{\text{all horiz}} = 19^{\text{ksi}} \cdot (0.531) = 10,089^{\#''}$$

Vertical loads shared with bottom rail or intermediate support

For vertical load \rightarrow bottom in tension top in compression.

$$F_b = 19 \text{ ksi}$$

For top rail acting alone

$$\text{bottom stress: } M_{\text{all vert}} = (0.129 \text{ in}^3) \cdot 19 \text{ ksi} = 2,451^{\#''} \text{ or}$$

Allowable loads

$$\text{Horizontal} \rightarrow \text{uniform} \rightarrow W_H = \frac{10,089 \cdot 8}{72^2} = 15.6 \text{ \#/in} = W_H = 186.8 \text{ plf}$$

$$P_H = \frac{4 \cdot 10,089}{72} = 560 \text{ \#}$$

$$\text{Vertical} \rightarrow W = \frac{2,451 \cdot 8}{72^2} = 3.78 \text{ \#/in} = 45.4 \text{ plf (Top rail alone)}$$

$$P = \frac{2,451 \cdot 4}{72} = 136^{\#}$$

For glass infill the glass will brace top rail and prevent its deflection downward.

Glass will act as beam web and transfer shear from top rail to bottom rail close to the connection to the post so that the load is almost pure shear in the end of the bottom rail.

Determine maximum span for top rail acting alone based on vertical loads:

$$L = 4 \cdot 2,451^{\#''} / 200^{\#} = 49'' \text{ for concentrated load}$$

$$L = \sqrt{[8 \cdot (2,451/12) / 50]} = 5.72' = 5' - 8 \frac{9}{16}''$$

EDWARD C. ROBISON, PE

10012 Creviston Dr NW

Gig Harbor, WA 98329

253-858-0855/Fax 253-858-0856 elrobison@narrows.com

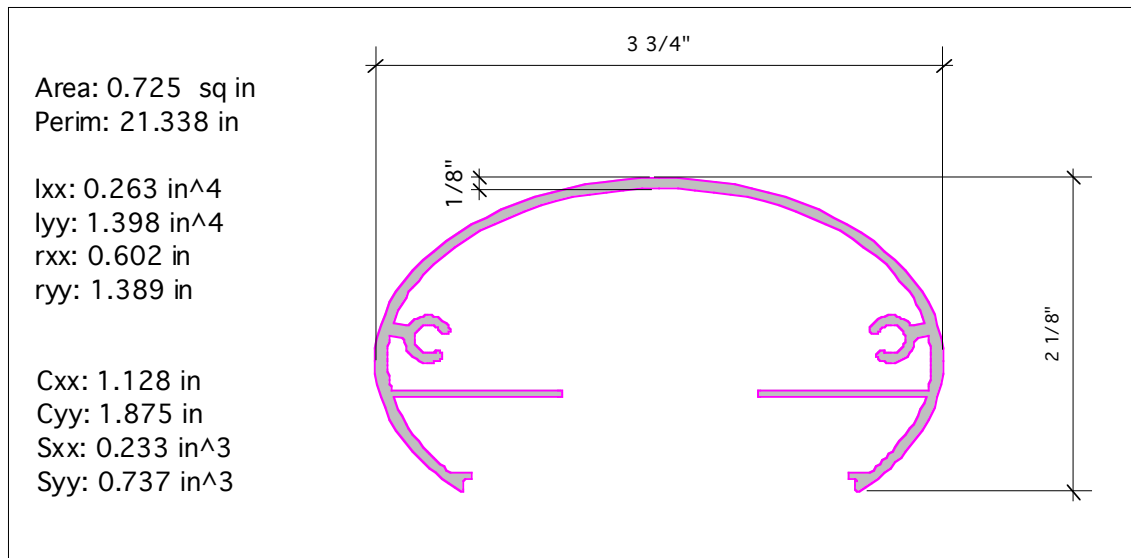
Top Rail Series 350

Allowable stresses ADM Table 2-24 6063-T6 Aluminum

$$F_{Cb} \rightarrow R_b/t = \frac{1.875''}{0.125} = 15 \quad \text{line 16.1}$$

Based on 72'' max post spacing

$$F_{Cb} = 18.5 - 0.593(15)^{1/2} = 16.20 \text{ ksi}$$

$$M_{\text{all horiz}} = 16.20^{\text{ksi}} \cdot (0.737) = 11,942''\#$$

Vertical loads shared with bottom rail

For vertical load \rightarrow bottom in tension top comp.

$$F_b = 18 \text{ ksi}$$

For top rail acting alone

$$M_{\text{all vert}} = (0.233\text{in}^3) \cdot 18 \text{ ksi} = 4,194''\# \quad \text{or Controls}$$

$$= (0.263\text{in}^4/0.997'') \cdot 16.20 \text{ ksi} = 4,273''\#$$

Allowable loads For 6' post spacing:

$$\text{Horizontal} \rightarrow \text{uniform} \rightarrow W_H = \frac{11,942 \cdot 8}{72^2} = 18.4 \text{ \#/in} = W_H = 221.1 \text{ plf}$$

$$P_H = \frac{4 \cdot 11,942}{72} = 663.4 \text{ \#}$$

$$\text{Vertical} \rightarrow W = \frac{4,194 \cdot 8}{72^2} = 6.5 \text{ \#/in} = 78 \text{ plf (Top rail alone)}$$

$$P = \frac{4,194 \cdot 4}{72} = 233 \text{ \#}$$

EDWARD C. ROBISON, PE

10012 Creviston Dr NW

Gig Harbor, WA 98329

253-858-0855/Fax 253-858-0856 elrobison@narrows.com

Series 400 Top rail

I_{xx} : 0.611 in⁴
 I_{yy} : 3.736 in⁴
 r_{xx} : 0.717 in
 r_{yy} : 1.774 in
 C_{xx} : 1.358 in
 C_{yy} : 2.50 in
 S_{xx} : 0.450 in³ bottom
 S_{xx} : 0.399 in³ top
 S_{yy} : 1.494 in³

6063-T6 Aluminum alloy

For 72" on center posts; $L = 72" - 2.375" - 1" \times 2 = 67.625"$;
 $kL_b = 1/2L = 33.81"$

$F_{bc} = 16.7 - 0.073 \cdot \frac{33.81}{1.774} = 15.3$ ksi From ADM Table 2-24

$F_t = 15$ ksi

Allowable Moments \rightarrow Horiz. = $1.494 \text{ in}^3 \cdot 15.0 \text{ ksi} = 22,410 \text{ in} \cdot \# = 1867.5 \text{ #}'$

Vertical load = $0.399 \text{ in}^3 \cdot 15 \text{ ksi} = 5,985 \text{ in} \cdot \# = 498.75 \text{ #}'$

Maximum allowable load for 72" o.c. post spacing - vertical

$W = 5,985 \text{ in} \cdot \# \cdot 8 / (67.625 \text{ in})^2 = 10.47 \text{ pli} = 125.6 \text{ plf}$

$P = 5,985 \text{ in} \cdot \# \cdot 4 / 67.625 \text{ in} = 354 \text{ #}$

Maximum span without load sharing, $P = 200 \text{ #}$

$S = 5,985 \text{ in} \cdot \# \cdot 4 / 200 \text{ #} = 119.7 \text{ in}$ clear,

$L = (8M_a / 50 \text{ plf})^{1/2} = (8 \cdot 498.75 / 50 \text{ plf})^{1/2} = 8.93'$

Max post spacing = $8' 11" + 2.375" = 9' 1-3/8"$

For horizontal load, maximum span for 50 plf load

$L = (8M_a / 50 \text{ plf})^{1/2} = (8 \cdot 1,867.5 / 50 \text{ plf})^{1/2} = 17.29'$

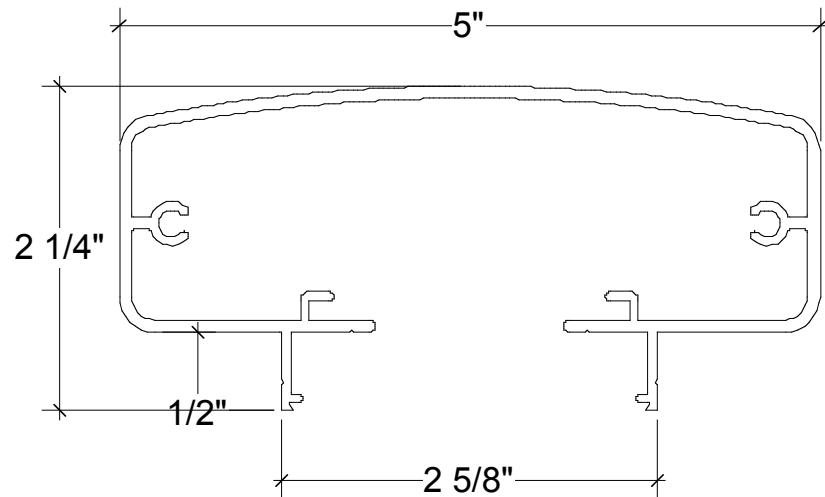

EDWARD C. ROBISON, PE

10012 Creviston Dr NW

Gig Harbor, WA 98329

253-858-0855/Fax 253-858-0856 elrobison@narrows.com

SERIES 400 TOP RAIL
COMPOSITE MATERIAL OR
Alloy 6063 – T6 Aluminum

$$I_{xx}: 0.0138 \text{ in}^4; I_{yy}: 0.265 \text{ in}^4$$

$$C_{xx}: 0.573 \text{ in}; C_{yy}: 1.344 \text{ in}$$

$$S_{xx}: 0.024 \text{ in}^3; S_{yy}: 0.197 \text{ in}^3$$

Wood – varies $G \geq 0.43$

2"x4" nominal

$$I_{xx}: 0.984 \text{ in}^4; I_{yy}: 5.359 \text{ in}^4$$

$$C_{xx}: 0.75 \text{ in}; C_{yy}: 1.75 \text{ in}$$

$$S_{xx}: 1.313 \text{ in}^3; S_{yy}: 3.063 \text{ in}^3$$

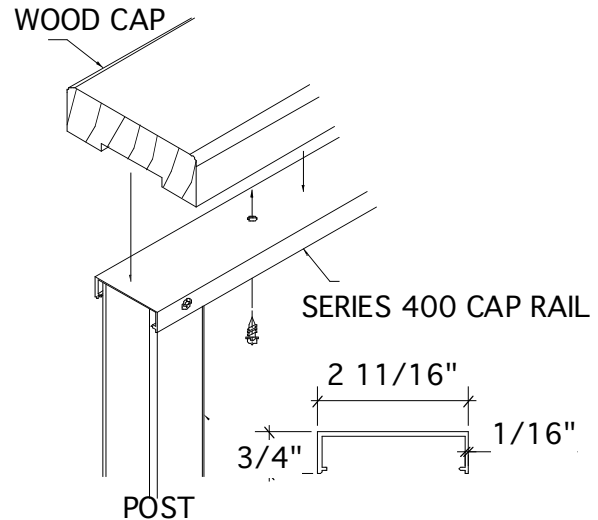

Allowable Stress for aluminum: ADM Table 2-24

$$F_T = 15 \text{ ksi}$$

$F_C \rightarrow 6'$ span

Rail is braced by wood At 16" o.c. and legs have stiffeners therefore

$$F_c = 15 \text{ ksi}$$

For wood use allowable stress from NDS Table 4A for lowest strength wood that may be used: $F_b = 725 \text{ psi}$ (mixed maple #1), $CD = 1.33$, $CF = 1.5$

$$F'_b = 725 * 1.33 * 1.5 = 1,445 \text{ psi}$$

$$F'_b = 725 * 1.33 * 1.5 * 1.1 = 1,590 \text{ psi for flat use (vertical loading)}$$

Composite action between aluminum and wood:

$$n = E_a/E_w = 10.1/1.1 = 9.18$$

The limiting stress on the aluminum = $9.18 * 1,445 \text{ psi} = 13,267 \text{ psi} < 15 \text{ ksi}$

Allowable Moments \rightarrow

$$\text{Horiz.} = 0.197 \text{ in}^3 * 13267 \text{ psi} + 3.063 \text{ in}^3 * 1445 \text{ psi} = 7040''\#$$

$$\text{Vertical load} = 0.024 \text{ in}^3 * 13267 \text{ ksi} + 1.313 * 1,590 = 2,405''\#$$

Maximum allowable load for 72" o.c. post spacing - Horizontal load

$$W = 7,040''\# * 8 / (69.625''^2) = 11.6 \text{ pli} = 139 \text{ plf}$$

$$P = 7,040''\# * 4 / 69.625'' = 404\#$$

Maximum span without load sharing, $P = 200\#$ or 50 lf - Vertical load

$$S = 2,405''\# * 4 / 200\# = 48.1'' \text{ clear}$$

$$\text{Max post spacing} = 48.1'' + 2.375'' = 50.475''$$

COMPOSITES: Composite materials, plastic lumber or similar may be used provided that the size and strength is comparable to the wood.

EDWARD C. ROBISON, PE

10012 Creviston Dr NW

Gig Harbor, WA 98329

253-858-0855/Fax 253-858-0856 elrobison@narrows.com

Glass Infill Bottom Rail

6063-T6

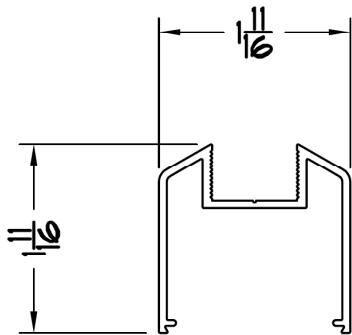

Area: 0.3923 sq in
Perim: 11.648 in
Ixx: 0.0869 in ⁴
Iyy: 0.172 in ⁴
Kxx: 0.472 in
Kyy: 0.662 in
Cxx: 1.0133 in
Cyy: 0.8435 in
Sxx: 0.0857 in ³ Bottom
Sxx: 0.129 in ³ Top
Syy: 0.204 in ³

For 72" on center posts; $L = 72'' - 2.375'' - 1'' \times 2 = 67.625''$; $L_b = 1/2L = 33.81''$
 $L_b/r_y = 33.81''/0.662 = 51.07$ From ADM Table 2-24
 $F_{bc} = 16.7 - 0.073 \cdot 51.07 = 12.97$ ksi

Allowable Moments → Horiz. = $0.204 \text{ in}^3 \cdot 12.97 \text{ ksi} = 2,646''\#$

Maximum allowable load for 72" o.c. post spacing

$$W = 2,646''\# \cdot 8 / (67.625''^2) = 4.63 \text{ pli} = 55.5 \text{ plf}$$

$$P = 2,646''\# \cdot 4 / 67.625'' = 156.5\#$$

Max span for 50 plf load = $(8 \cdot 2,646 / (50/12))^{1/2} = 71.28''$ clear span

Rail fasteners -Bottom rail connection block to post
 #10x1.5" 55 PHP SMS Screw

Check shear @ post (6005-T5)

$2 \times F_{upost} \times \text{dia screw} \times \text{Post thickness} \times \text{SF}$

$$V = 2 \cdot 38 \text{ ksi} \cdot 0.1697'' \cdot 0.10'' \cdot \frac{1}{3} (\text{FS}) =$$

$$V = 430\#/\text{screw}$$

Since minimum of 2 screws used for each

$$\text{Allowable load} = 2 \cdot 430\# = 860\#$$

Rail Connection to RCB

2 screws each en

#8 Tek screw to 6063-T6

$$2 \cdot 30 \text{ ksi} \cdot 0.1309'' \cdot 0.07'' \cdot \frac{1}{3} = 232\#/\text{screw}$$

$$\text{Allowable tension} = 2 \cdot 232 = 464\#$$

OK

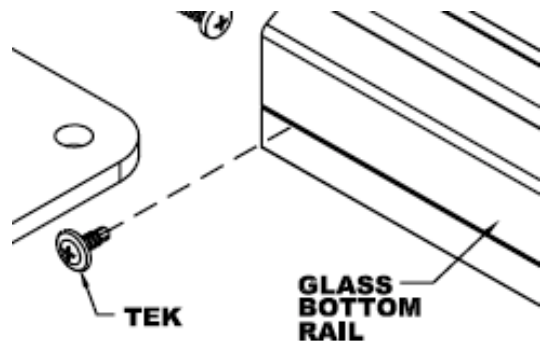
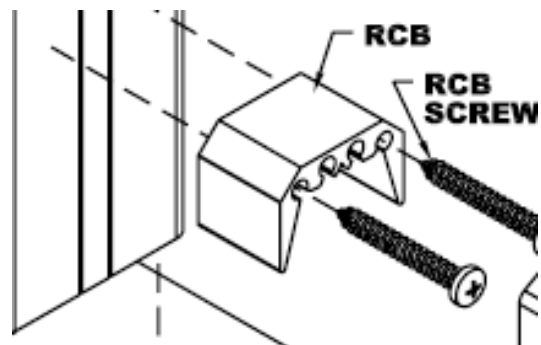

EDWARD C. ROBISON, PE

10012 Creviston Dr NW

Gig Harbor, WA 98329

253-858-0855/Fax 253-858-0856 elrobison@narrows.com

Picket bottom rail

Bottom rail strength

6063-T6 Aluminum alloy

For 72" on center posts; $L = 72'' - 2.375'' - 1'' \times 2 = 67.625''$; $L_b = 1/2L = 33.81''$

$F_{bc} = 16.7 - 0.073 \cdot \frac{33.81}{0.658} = 12.95 \text{ ksi}$ From

ADM Table 2-24 line 11 for compression or line 2 for tension

$F_t = 15 \text{ ksi}$

Allowable Moments \rightarrow Horiz. = $0.227 \text{ in}^3 \cdot 12.95 \text{ ksi} = 2,939''\#$

Maximum allowable load for 72" o.c. post spacing

$W = 2,939''\# \cdot 8 / (67.625''^2) = 5.14 \text{ pli} = 62.7 \text{ plf}$

$P = 2,939''\# \cdot 4 / 67.625'' = 173.8\#$

Rail fasteners -Bottom rail connection block to post

#10x1.5" 55 PHP SMS Screw

Check shear @ post (6005-T5)

$2 \times F_{upost} \times \text{dia screw} \times \text{Post thickness} \times \text{SF}$
Eq 5.4.3-2

$V = 38 \text{ ksi} \cdot 0.19'' \cdot 0.1'' \cdot \frac{1}{3 \text{ (FS)}} =$

$V = 240\#/\text{screw}$

Since minimum of 2 screws used for each

Allowable load = $2 \cdot 240\# = 480\#$

Rail Connection to RCB

2 screws each end

#8 Tek screw to 6063-T6

ADM Eq. 5.4.3-1

$2 \cdot 30 \text{ ksi} \cdot 0.1248'' \cdot 0.07'' \cdot \frac{1}{3} = 175\#/\text{screw}$

Allowable shear = $2 \cdot 175 = 350\#$

OK

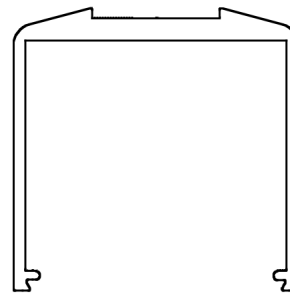

Area: 0.446 sq in
Perim: 9.940 in

Ixx: 0.125 in⁴
Iyy: 0.193 in⁴
Kxx: 0.529 in
Kyy: 0.658 in

Cxx: 1.151 in
Cyy: 0.852 in
Sxx: 0.108 in³
Syy: 0.227 in³

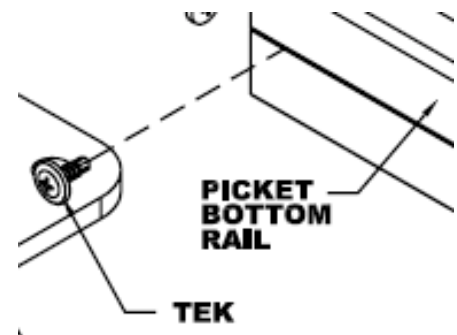
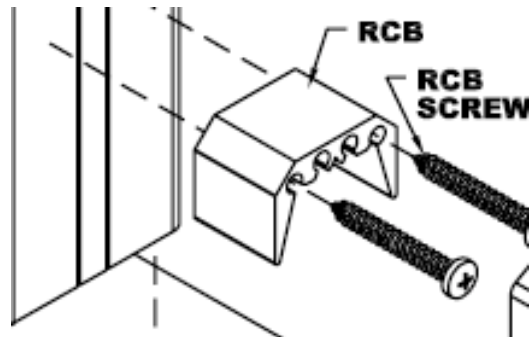

EDWARD C. ROBISON, PE

10012 Creviston Dr NW

Gig Harbor, WA 98329

253-858-0855/Fax 253-858-0856 elrobison@narrows.com

MID RAIL

$$I_{xx} = 0.123 \text{ in}^4$$

$$I_{yy} = 0.177 \text{ in}^4$$

$$S_{xx} = 0.115 \text{ in}^3$$

$$S_{yy} = 0.209 \text{ in}^3$$

$$r_{xx} = 0.579 \text{ in}$$

$$r_{yy} = 0.695 \text{ in}$$

Allowable stresses ADM Table 2-24 6063-T6 Aluminum

$F_t = 18 \text{ ksi}$ For vertical loads

$$F_{Cb} \rightarrow R_b/t = \frac{1.25''}{3.75} = 0.33 \leq 1.6 \text{ line 16.1 } F_{Cb} = 18 \text{ ksi}$$

$$M_{\text{all vert}} = 18^{\text{ksi}} \cdot (0.115) = 2,070''\#$$

For horizontal loads:

$F_t = 15 \text{ ksi}$ For vertical loads

$$F_{Cb} \rightarrow L_b/r_y = \frac{35''}{0.695} = 50.4 \text{ line 11}$$

Based on 72" max post spacing

$$F_{Cb} = (16.7 - 0.073 \cdot 50.4) \text{ ksi} = 13.0 \text{ ksi}$$

$$M_{\text{all horiz}} = 13^{\text{ksi}} \cdot (0.209) = 2,717''\#$$

For intermediate rail acting alone

Allowable loads

$$\text{Horizontal} \rightarrow \text{uniform} \rightarrow W_H = \frac{2,717 \cdot 8}{70^2} = 4.44 \text{ \#/in} = W_H = 53 \text{ plf}$$

$$P_H = \frac{4 \cdot 2,717}{70} = 155 \text{ \#} \text{ Not used for top rail 50\# conc load appl.}$$

$$\text{Vertical} \rightarrow W = \frac{2070 \cdot 8}{70^2} = 3.38 \text{ \#/in} = 40.6 \text{ plf (Top rail alone)}$$

$$P = \frac{2070 \cdot 4}{70} = 118 \text{ \#} \text{ Not used for top rail 50\# conc load appl.}$$

Maximum wind load for 3'6" lite height, 1'9" tributary width

$$W_{\text{max}} = 53/1.75 = 30.3 \text{ plf}$$

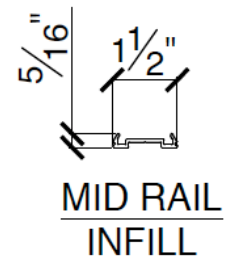
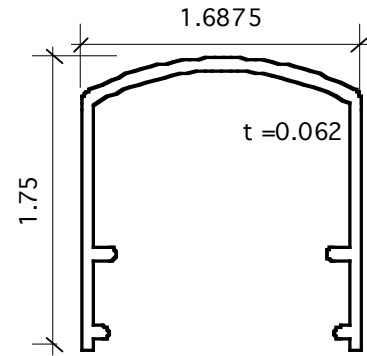

EDWARD C. ROBISON, PE

10012 Creviston Dr NW

Gig Harbor, WA 98329

253-858-0855/Fax 253-858-0856 elrobison@narrows.com

WIND SCREEN MID RAIL

Standard bottom rail with infill

Refer to bottom rail calculations for rail properties.

Check bottom rail strength for span used in privacy screen.

Midrail glass infill when installed in rail will stiffen the flanges (legs) continuously so that the flanges are equivalent to flat elements supported on both edges:

From ADM Table 2-24 section 16.

$$b/t = 1.1''/0.07 = 15.7 < 23$$

Therefore $F_{ca} = 15$ ksi

Strength of infill piece:

$$I_{xx}: 0.0162 \text{ in}^4$$

$$I_{yy}: 0.0378 \text{ in}^4$$

$$S_{xx}: 0.0422 \text{ in}^3$$

$$S_{yy}: 0.0490 \text{ in}^3$$

$F_{ca} = 15$ ksi

When inserted into bottom rail determine the effective strength:

ratio of load carried by infill:

$$I_{yy} \text{ infill} / I_{yy} \text{ rail} = 0.0378/0.172 = 0.22$$

$$S_{yy} \text{ infill} \leq 0.22 * 0.204 = .045 < 0.049$$

Allowable Moments → Horiz. = $(0.204 \text{ in}^3 + 0.045) * 15 \text{ ksi} = 3,735''\#$

Maximum allowable load for 70'' screen width $L = 70'' - 1'' * 2 - 2.375 * 2 = 63.25''$

$$W = 3,735''\# * 8 / (63.25''^2) = 7.5 \text{ pli} = 90 \text{ plf}$$

$$P = 3,735''\# * 4 / 63.25'' = 236\#$$

Maximum allowable load for 60'' screen width $L = 60'' - 1'' * 2 - 2.375 * 2 = 53.25''$

$$W = 3,735''\# * 8 / (53.25''^2) = 10.5 \text{ pli} = 126 \text{ plf}$$

$$P = 3,735''\# * 4 / 53.25'' = 280\#$$

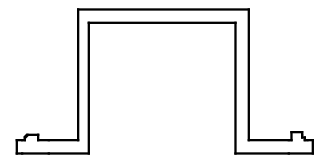
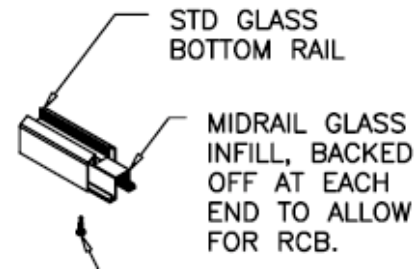

EDWARD C. ROBISON, PE

10012 Creviston Dr NW

Gig Harbor, WA 98329

253-858-0855/Fax 253-858-0856 elrobison@narrows.com

STANDARD POST RAIL CONNECTION BLOCK

Can be used to connect top, mid and bottom rails to standard or 4"x4" post face, walls or other end butt connection conditions.

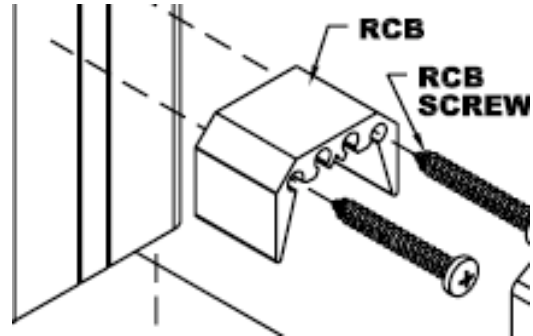

Rail snaps over block and is secured with either silicone adhesive or #8 tek screws.

Connection strength to post or wall: (2) #10x1.5" 55 PHP SMS Screw

Check shear @ post (6005-T5)

$F_{upost} \times \text{dia screw} \times \text{Post thickness} \times \text{SF}$

Eq 5.4.3-2

$$V = 38 \text{ ksi} \cdot 0.19" \cdot 0.1" \cdot \frac{1}{3 \text{ (FS)}} = 240\#/\text{screw} \text{ for standard post}$$

Since minimum of 2 screws used for each, Allowable load = $2 \cdot 240\# = 480\#$

For 4"x4" post:

$$V = 38 \text{ ksi} \cdot 0.19" \cdot 0.15" \cdot \frac{1}{3 \text{ (FS)}} = 360\#/\text{screw} \text{ for standard post}$$

Since minimum of 2 screws used for each, Allowable load = $2 \cdot 360\# = 720\#$

Connections to walls and other surfaces is dependant on supporting material. Alternative fasteners may be used for connections to steel, concrete or wood.

For connection to wood post:

(2) #10 x2-1/2" wood screws strength from NDS Table 11M, $G \geq 0.43$

$$Z' = \# \cdot C_D \cdot Z = 2 \text{ screws} \cdot 1.33 \cdot 140\# = 372\#$$

For connection to cold formed steel stud - 22 ga min based on CCFSS T.B. V2#1

$$Z = 2 \cdot 175\# = 350\#$$

For connection to concrete or CMU - (2) 3/16" x 2" Tapcon screws

$$Z = 2 \cdot 290 = 580\#$$

EDWARD C. ROBISON, PE

10012 Creviston Dr NW

Gig Harbor, WA 98329

253-858-0855/Fax 253-858-0856 elrobison@narrows.com

WALL MOUNT END CAPS

End cap is fastened to the top rail with

2) #10x1” 55 PHP SMS Screws

2x F_{upost}x dia screw x Cap thickness x SF

Eq 5.4.3-2

$$V = 2 * 38 \text{ ksi} * 0.19" * 0.15" * \frac{1}{3 \text{ (FS)}} =$$

722#/screw , 1,444# per connection

Connection to wall shall use either:

#14x1-1/2” wood screw to wood, minimum 1” penetration into solid wood.

Allowable load = 2*175# = 350#

Wood shall have a G ≥ 0.43

From NDS Table 11M

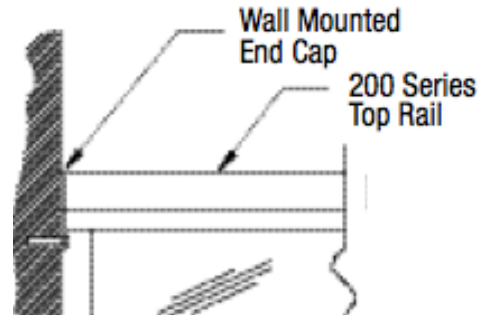

For connection to steel studs or sheet metal blocking

Use #12 self drilling screws.

Minimum metal thickness is 18 gauge, 43 mil (0.0451”)

Allowable load = 280#/screw

Table 3: Suggested Capacity for Screws Connecting Steel to Steel (lbs.)

Steel Thickness - Thinnest Component	1/4 -14 Screw		#12-14 Screw		#10-16 Screw *		#8-18 Screw *		#6 Screw *	
	Shear	Pullout	Shear	Pullout	Shear	Pullout	Shear	Pullout	Shear	Pullout
0.1017"	1000	320	890	280	780	245	675	210	560	175
0.0713"	600	225	555	195	520	170	470	145	395	125
0.0566"	420	180	390	155	370	135	340	115	310	95
0.0451"	300	140	280	120	260	105	240	90	220	75
0.0347"	200	110	185	95	175	80	165	70	150	60

Notes:

- Design values are based on CCFSS Technical Bulletin Vol. 2, No. 1 which outlines the proposed AISI Specification provisions for screw connections. For shear connections the cold-formed steel section should be evaluated for tension.
- Based on F_y = 33ksi, F_u = 45ksi minimum. Adjust values for other steel strengths.
- * = Refer to Table 1 for limits on recommended total steel thickness of connected parts.

EDWARD C. ROBISON, PE

10012 Creviston Dr NW

Gig Harbor, WA 98329

253-858-0855/Fax 253-858-0856 elrobison@narrows.com

Wall Mounted End Caps – Cont.

For connection to masonry or concrete use 3/16 screw-in anchor-
 Allowable shear load ≥ 290# per Tapcon

ESR-2202 | Most Widely Accepted and Trusted

Page 5 of 5

**TABLE 2—EXAMPLE ALLOWABLE STRESS DESIGN VALUES FOR ILLUSTRATIVE PURPOSES
 FOR TAPCON WITH ADVANCED THREADFORM TECHNOLOGY ANCHOR^{1,2,3,4,5,6,7,8}**

NOMINAL ANCHOR DIAMETER (inch)	EFFECTIVE EMBEDMENT DEPTH (inches)	ALLOWABLE LOADS (pounds)				
		Tension				Shear
		2,500 psi	3,000 psi	4,000 psi	5,000 psi	2,500 psi
3/16	1.5	260	285	330	370	290
1/4	1.5	350	385	445	495	525

For SI: 1 inch = 25.4 mm, 1 lbf = 4.45 N, 1 psi = 0.006895 MPa.

- ¹Single anchor with static tension load only.
- ²Concrete determined to remain uncracked for the life of the anchorage.
- ³Load combination 9-2 from ACI 318 Section 9.2 (no seismic loading).
- ⁴Thirty percent dead load and 70 percent live load, controlling load combination 1.2D + 1.6L.
- ⁵Calculation of weighted average for $\alpha = 0.3 \cdot 1.2 + 0.7 \cdot 1.6 = 1.48$.
- ⁶Normal weight concrete
- ⁷ $c_{a1} = c_{a2} > c_{ac}$.
- ⁸ $h \geq h_{min}$.
- ⁹Condition B in accordance with ACI 318 Section D.4.4 applies.

300 and 350 Series end caps use same fasteners and have identical strengths

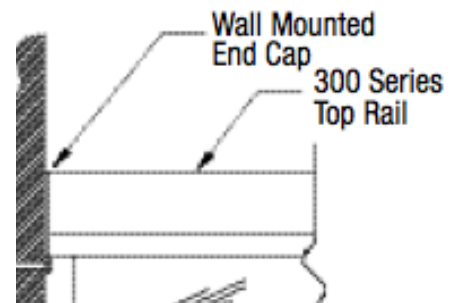
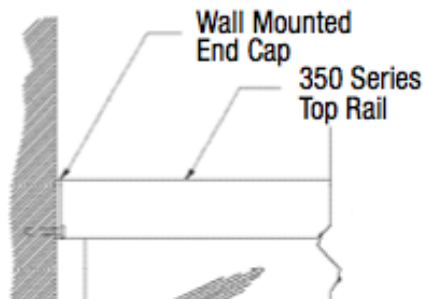

Excerpts from National Design Specifications For Wood Construction

Table 11.2A Lag Screw Reference Withdrawal Design Values, W¹

Tabulated withdrawal design values (W) are in pounds per inch of thread penetration into side grain of wood member.
Length of thread penetration in main member shall not include the length of the tapered tip (see 11.2.1.1).

Specific Gravity, G ²	Lag Screw Diameter, D										
	1/4"	5/16"	3/8"	7/16"	1/2"	5/8"	3/4"	7/8"	1"	1-1/8"	1-1/4"
0.73	397	469	538	604	668	789	905	1016	1123	1226	1327
0.71	381	450	516	579	640	757	868	974	1077	1176	1273
0.68	357	422	484	543	600	709	813	913	1009	1103	1193
0.67	349	413	473	531	587	694	796	893	987	1078	1167
0.58	281	332	381	428	473	559	641	719	795	869	940
0.55	260	307	352	395	437	516	592	664	734	802	868
0.51	232	274	314	353	390	461	528	593	656	716	775
0.50	225	266	305	342	378	447	513	576	636	695	752
0.49	218	258	296	332	367	434	498	559	617	674	730
0.47	205	242	278	312	345	408	467	525	580	634	686
0.46	199	235	269	302	334	395	453	508	562	613	664
0.44	186	220	252	283	312	369	423	475	525	574	621
0.43	179	212	243	273	302	357	409	459	508	554	600
0.42	173	205	235	264	291	344	395	443	490	535	579
0.41	167	198	226	254	281	332	381	428	473	516	559
0.40	161	190	218	245	271	320	367	412	455	497	538
0.39	155	183	210	236	261	308	353	397	438	479	518
0.38	149	176	202	227	251	296	340	381	422	461	498
0.37	143	169	194	218	241	285	326	367	405	443	479
0.36	137	163	186	209	231	273	313	352	389	425	460
0.35	132	156	179	200	222	262	300	337	373	407	441
0.31	110	130	149	167	185	218	250	281	311	339	367

1. Tabulated withdrawal design values, W, for lag screw connections shall be multiplied by all applicable adjustment factors (see Table 10.3.1).
2. Specific gravity, G, shall be determined in accordance with Table 11.3.3A.

EDWARD C. ROBISON, PE

10012 Creviston Dr NW

Gig Harbor, WA 98329

253-858-0855/Fax 253-858-0856 elrobison@narrows.com

Table 11K LAG SCREWS: Reference Lateral Design Values, Z, for Single Shear (two member) Connections^{1,2,3,4}



for sawn lumber or SCL with ASTM A653, Grade 33 steel side plate (for $t_s < 1/4"$) or ASTM A36 steel side plate (for $t_s = 1/4"$)
 (tabulated lateral design values are calculated based on an assumed length of lag screw penetration, p, into the main member equal to 8D)

Side Member Thickness t_s in.	Lag Screw Diameter D in.	G=0.67 Red Oak		G=0.55 Mixed Maple Southern Pine		G=0.5 Douglas Fir-Larch		G=0.49 Douglas Fir-Larch (N)		G=0.46 Douglas Fir(S) Hem-Fir(N)		G=0.43 Hem-Fir		G=0.42 Spruce-Pine-Fir		G=0.37 Redwood (open grain)		G=0.36 Eastern Softwoods Spruce-Pine-Fir(S) Western Cedars Western Woods		G=0.35 Northern Species	
		$Z_{ }$ lbs.	Z_{\perp} lbs.	$Z_{ }$ lbs.	Z_{\perp} lbs.	$Z_{ }$ lbs.	Z_{\perp} lbs.	$Z_{ }$ lbs.	Z_{\perp} lbs.	$Z_{ }$ lbs.	Z_{\perp} lbs.	$Z_{ }$ lbs.	Z_{\perp} lbs.	$Z_{ }$ lbs.	Z_{\perp} lbs.	$Z_{ }$ lbs.	Z_{\perp} lbs.	$Z_{ }$ lbs.	Z_{\perp} lbs.	$Z_{ }$ lbs.	Z_{\perp} lbs.
0.075 (14 gage)	1/4	170	130	160	120	150	110	150	110	150	100	140	100	140	100	130	90	130	90	130	90
	5/16	220	160	200	140	190	130	190	130	190	130	180	120	180	120	170	110	170	110	160	100
	3/8	220	160	200	140	200	130	190	130	190	120	180	120	180	120	170	110	170	100	170	100
0.105 (12 gage)	1/4	180	140	170	130	160	120	160	120	160	110	150	110	150	110	140	100	140	100	140	90
	5/16	230	170	210	150	200	140	200	140	190	130	190	120	190	120	180	110	170	110	170	110
	3/8	230	160	210	140	200	140	200	130	200	130	190	120	190	120	180	110	180	110	170	110
0.120 (11 gage)	1/4	190	150	180	130	170	120	170	120	160	120	160	110	160	110	150	100	150	100	140	100
	5/16	230	170	210	150	210	140	200	140	200	140	190	130	190	130	180	120	180	120	180	110
	3/8	240	170	220	150	210	140	210	140	200	130	200	130	190	120	180	110	180	110	180	110
0.134 (10 gage)	1/4	200	150	180	140	180	130	170	130	170	120	160	120	160	110	150	110	150	100	150	100
	5/16	240	180	220	160	210	150	210	140	200	140	200	130	200	130	190	120	180	120	180	120
	3/8	240	170	220	150	220	140	210	140	210	140	200	130	200	130	190	120	190	120	180	110
0.179 (7 gage)	1/4	220	170	210	150	200	150	200	140	190	140	190	130	190	130	180	120	170	120	170	120
	5/16	260	190	240	170	230	160	230	160	230	150	220	150	220	150	210	130	200	130	200	130
	3/8	270	190	250	170	240	160	240	160	230	150	220	140	220	140	210	130	210	130	200	130
0.239 (3 gage)	1/4	240	180	220	160	210	150	210	150	200	140	190	140	190	130	180	120	180	120	180	120
	5/16	300	220	280	190	270	180	260	180	260	170	250	160	250	160	230	150	230	150	230	140
	3/8	310	220	280	190	270	180	260	170	250	160	250	160	240	140	230	140	230	140	230	140
	7/16	420	290	390	260	380	240	370	240	360	230	350	220	350	220	330	200	330	200	320	190
	1/2	510	340	470	300	460	290	450	280	440	270	430	260	420	260	400	240	400	230	390	230
	5/8	770	490	710	430	680	400	660	380	640	370	630	360	600	330	590	330	590	330	580	320
	3/4	1110	670	1020	590	980	560	970	550	950	530	920	500	910	500	860	450	850	450	840	440
	7/8	1510	880	1390	780	1330	730	1320	710	1280	690	1250	650	1230	650	1170	590	1160	590	1140	570
	1	1940	1100	1780	960	1710	910	1700	890	1650	860	1600	820	1590	810	1500	740	1480	730	1460	710
	1/4	1/4	240	180	220	160	210	150	210	150	200	140	200	140	190	130	180	120	180	120	180
5/16		310	220	280	200	270	180	270	180	260	170	250	170	250	160	230	150	230	150	230	140
3/8		320	220	290	190	280	180	270	180	270	170	260	160	250	160	240	150	240	140	230	140
7/16		480	320	440	280	420	270	420	260	410	250	390	240	390	230	370	220	360	210	360	210
1/2		580	390	540	340	520	320	510	320	500	310	480	290	480	290	460	270	450	260	440	260
5/8		850	530	780	470	750	440	740	440	720	420	700	400	690	400	660	370	650	360	640	350
3/4		1200	730	1100	640	1060	600	1050	590	1020	570	990	540	980	530	930	490	920	480	900	470
7/8	1600	930	1470	820	1410	770	1400	750	1360	720	1320	690	1310	680	1240	630	1220	620	1200	600	
1	2040	1150	1870	1000	1800	950	1780	930	1730	900	1680	850	1660	840	1570	770	1550	760	1530	740	

1. Tabulated lateral design values, Z, shall be multiplied by all applicable adjustment factors (see Table 10.3.1).
2. Tabulated lateral design values, Z, are for "reduced body diameter" lag screws (see Appendix Table L2) inserted in side grain with screw axis perpendicular to wood fibers; screw penetration, p, into the main member equal to 8D; dowel bearing strengths, F_{\perp} , of 61,850 psi for ASTM A653, Grade 33 steel and 87,000 psi for ASTM A36 steel and screw bending yield strengths, $F_{b,s}$, of 70,000 psi for $D = 1/4"$, 60,000 psi for $D = 5/16"$, and 45,000 psi for $D \geq 3/8"$.
3. Where the lag screw penetration, p, is less than 8D but not less than 4D, tabulated lateral design values, Z, shall be multiplied by $p/8D$ or lateral design values shall be calculated using the provisions of 11.3 for the reduced penetration.
4. The length of lag screw penetration, p, not including the length of the tapered tip, E (see Appendix Table L2), of the lag screw into the main member shall not be less than 4D. See 11.1.4.6 for minimum length of penetration, p_{min} .

Table 11M WOOD SCREWS: Reference Lateral Design Values, Z, for Single Shear (two member) Connections^{1,2,3}

for sawn lumber or SCL with ASTM 653, Grade 33 steel side plate
(tabulated lateral design values are calculated based on an assumed length of wood screw penetration, p, into the main member equal to 10D)

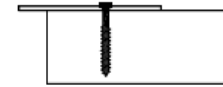

Side Member Thickness <i>t_r</i> in.	Wood Screw Diameter <i>D</i> in.	Wood Screw Number	G=0.67	G=0.55	G=0.5	G=0.49	G=0.46	G=0.43	G=0.42	G=0.37	G=0.36	G=0.35
			Red Oak	Mixed Maple Southern Pine	Douglas Fir-Larch	Douglas Fir-Larch(N)	Douglas Fir(S) Hem-Fir(N)	Hem-Fir	Spruce-Pine-Fir	Redwood (open grain)	Eastern Softwoods Spruce-Pine-Fir(S) Western Cedars Western Woods	Northern Species
			lbs.	lbs.	lbs.	lbs.	lbs.	lbs.	lbs.	lbs.	lbs.	lbs.
0.036 (20 gage)	0.138	6	89	76	70	69	66	62	60	54	53	52
	0.151	7	99	84	78	76	72	68	67	60	59	57
	0.164	8	113	97	89	87	83	78	77	69	67	66
0.048 (18 gage)	0.138	6	90	77	71	70	67	63	61	55	54	53
	0.151	7	100	85	79	77	74	69	68	61	60	58
	0.164	8	114	98	90	89	84	79	78	70	69	67
0.060 (16 gage)	0.138	6	92	79	73	72	68	64	63	57	56	54
	0.151	7	101	87	81	79	75	71	70	63	61	60
	0.164	8	116	100	92	90	86	81	79	71	70	68
	0.177	9	136	116	107	105	100	94	93	83	82	79
	0.190	10	146	125	116	114	108	102	100	90	88	86
0.075 (14 gage)	0.138	6	95	82	76	75	71	67	66	59	58	57
	0.151	7	105	90	84	82	78	74	72	65	64	62
	0.164	8	119	103	95	93	89	84	82	74	73	71
	0.177	9	139	119	110	108	103	97	95	86	84	82
	0.190	10	150	128	119	117	111	105	103	92	91	88
	0.216	12	186	159	147	145	138	130	127	114	112	109
0.105 (12 gage)	0.242	14	204	175	162	158	151	142	139	125	123	120
	0.138	6	104	90	84	82	79	74	73	66	65	63
	0.151	7	114	99	92	90	86	81	80	72	71	69
	0.164	8	129	111	103	102	97	92	90	81	80	77
	0.177	9	148	128	119	116	111	105	103	93	91	89
	0.190	10	160	138	128	125	120	113	111	100	98	96
	0.216	12	196	168	156	153	146	138	135	122	120	116
0.120 (11 gage)	0.242	14	213	183	170	167	159	150	147	132	130	126
	0.138	6	110	95	89	87	83	79	77	70	68	67
	0.151	7	120	104	97	95	91	86	84	76	75	73
	0.164	8	135	117	109	107	102	96	94	85	84	82
	0.177	9	154	133	124	121	116	110	107	97	95	93
	0.190	10	166	144	133	131	125	118	116	104	103	100
	0.216	12	202	174	162	159	152	143	140	126	124	121
0.134 (10 gage)	0.242	14	219	189	175	172	164	155	152	137	134	131
	0.138	6	116	100	93	92	88	83	81	73	72	70
	0.151	7	126	110	102	100	96	91	89	80	79	77
	0.164	8	141	122	114	112	107	101	99	89	88	86
	0.177	9	160	139	129	127	121	114	112	101	100	97
	0.190	10	173	149	139	136	130	123	121	109	107	104
	0.216	12	209	180	167	164	157	148	145	131	129	126
0.179 (7 gage)	0.242	14	226	195	181	177	169	160	157	141	139	135
	0.138	6	126	107	99	97	92	86	84	76	74	72
	0.151	7	139	118	109	107	102	95	93	84	82	80
	0.164	8	160	136	126	123	117	110	108	96	95	92
	0.177	9	184	160	148	145	138	129	127	113	111	108
	0.190	10	198	172	159	156	149	140	137	122	120	117
	0.216	12	234	203	189	186	178	168	165	149	146	143
0.239 (3 gage)	0.242	14	251	217	202	198	190	179	176	159	156	152
	0.138	6	126	107	99	97	92	86	84	76	74	72
	0.151	7	139	118	109	107	102	95	93	84	82	80
	0.164	8	160	136	126	123	117	110	108	96	95	92
	0.177	9	188	160	148	145	138	129	127	113	111	108
	0.190	10	204	173	159	156	149	140	137	122	120	117
	0.216	12	256	218	201	197	187	176	172	154	151	147
0.242	14	283	241	222	217	207	194	190	170	167	162	

1. Tabulated lateral design values, Z, shall be multiplied by all applicable adjustment factors (see Table 10.3.1).
2. Tabulated lateral design values, Z, are for rolled thread wood screws (see Appendix L) inserted in side grain with screw axis perpendicular to wood fibers; screw penetration, p, into the main member equal to 10D; dowel bearing strength, F_{eb} , of 61,850 psi for ASTM A653, Grade 33 steel and screw bending yield strengths, F_{yb} , of 100,000 psi for $0.099" \leq D \leq 0.142"$, 90,000 psi for $0.142" < D \leq 0.177"$, 80,000 psi for $0.177" < D \leq 0.236"$, 70,000 psi for $0.236" < D \leq 0.273"$.
3. Where the wood screw penetration, p, is less than 10D but not less than 6D, tabulated lateral design values, Z, shall be multiplied by p/10D or lateral design values shall be calculated using the provisions of 11.3 for the reduced penetration.

EDWARD C. ROBISON, PE
10012 Creviston Dr NW
Gig Harbor, WA 98329
253-858-0855/Fax 253-858-0856 elrobison@narrows.com

VERTICAL PICKET INSTALLATIONS**LOAD CASES:**

Picket rail Dead load = 5 plf for 42" rail height or less.

Loading:

Horizontal load to top rail from in-fill:

25 psf*H/2

Post moments

$$M_i = 25 \text{ psf} * H/2 * S * H = \\ = (25/2) * S * H^2$$

For top rail loads:

$$M_c = 200\# * H$$

$$M_u = 50\text{plf} * S * H$$

For wind load surface area:

Pickets 3/4" wide by 4" on center

Top rail = 3" maximum

Post = 2.375"

Area for typical 5' section by 42" high:

$$42'' * 2.375'' + 3'' * 60'' + 1.7'' * 57.625''$$

$$+ 0.75 * 36 * 18 = 863.7 \text{ in}^2$$

$$\% \text{ surface/area} = 863.7 / (60'' * 42'') = 34.3\%$$

$$\text{Wind load for 25 psf equivalent load} = 25 / 0.343 = 72.9 \text{ psf}$$

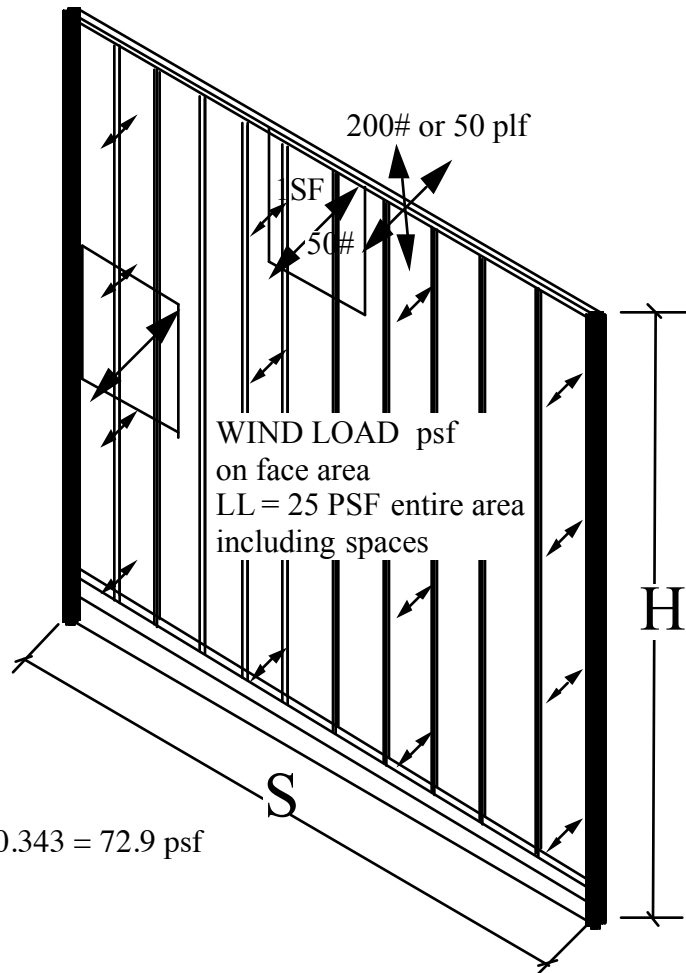

EDWARD C. ROBISON, PE

10012 Creviston Dr NW

Gig Harbor, WA 98329

253-858-0855/Fax 253-858-0856 elrobison@narrows.com

Picket Railing

Series 100

Top rail loading
50 plf or 200 lb conc.

Infill: 25 psf
Bottom rail loading
50 lb conc.

Picket infill panel is

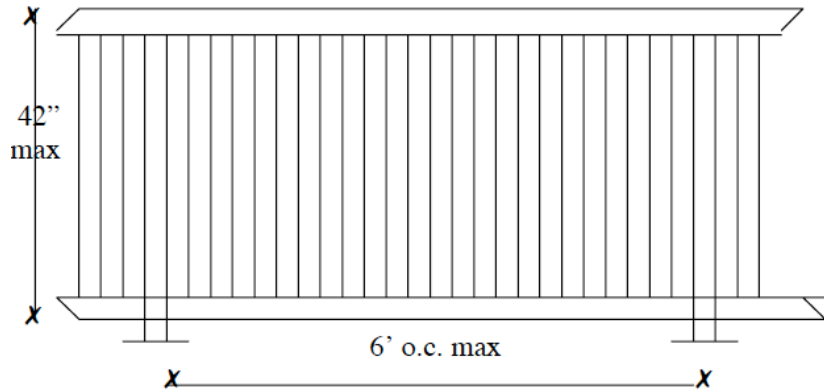

Loading → 25 psf → 4
1/2" O.C → 25psf · .375 = 9.4 plf

$$M = \frac{9.4/12 (42'' - 6'')^2}{8} = 127 \text{ lb-in}$$

For 5/8" Square pickets $t = 0.062'' \rightarrow S = 0.625^3/6 - 0.5^3/6 = 0.020 \text{ in}^3$
 $f_b = \frac{127 \text{ lb-in}}{0.02 \text{ in}^3} = 6,350 \text{ psi}$

For 50 lb conc load → 1 SF - min 2 pickets

$$M = \frac{50/2 \cdot 36''}{4} = 225 \text{ lb-in}$$

$$f_b = \frac{225 \text{ lb-in}}{0.02 \text{ in}^3} = 11,250 \text{ psi}$$

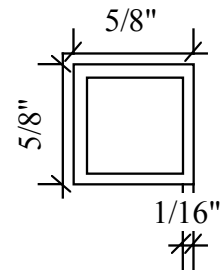

6063-T6 $F_b = 15 \text{ ksi}$ – compression ADM Table 2-24 line 14
 15 ksi – tension ADM Table 2-24 line 2
 Maximum allowable moment on picket = 15 ksi * 0.02 in³ = 300 in-lb
 Maximum span = 300 in-lb * 4/25 lb = 48" – concentrated load or
 (300 in-lb * 8 / 0.783 lb/in)^{1/2} = 55.4 in

Connections

Pickets to top and bottom rails direct bearing –ok
 Lap into top and bottom rail – 1" into bottom rail and 5/8" into top rail.

Allowable bearing pressure = 21 ksi (ADM Table 2-24 line 6)
 Picket filler snaps between pickets to pressure lock pickets in place.
 Bearing surface = 1.375" * .062" = 0.085 in²
 Allowable bearing = 0.085 in² * 21 ksi = 1,785#
 Withdrawal prevented by depth into rails.

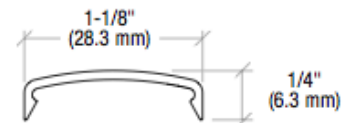

PICKETS 3/4" ROUND

Loading → 25 psf → 4 1/2" O.C → 25psf · .375 = 9.4 plf

$$M = \frac{9.4/12 (42'' - 6'')^2}{8} = 127 \text{ lb-in}$$

or concentrated = 50# on 1 sf

For 3/4" round pickets $t = 0.062''$ →

Area: 0.170 sq in

$$I_{xx}: 0.0093 \text{ in}^4 \quad S_{xx}: 0.022 \text{ in}^3$$

$$I_{yy}: 0.0083 \text{ in}^4 \quad S_{yy}: 0.022 \text{ in}^3$$

$$r_{xx}: 0.234267 \text{ in}$$

$$r_{yy}: 0.221764 \text{ in}$$

$$f_b = \frac{127 \text{ lb-in}}{0.022 \text{ in}^3} = 5,773 \text{ psi}$$

For 50 lb conc load → 1 SF - min 2 pickets

$$M = \frac{50/2 \cdot 36''^2}{4} = 225 \text{ lb-in}$$

$$f_b = \frac{225 \text{ lb-in}}{0.022 \text{ in}^3} = 10,227 \text{ psi}$$

6063-T6 $F_b = 15 \text{ ksi}$ – compression ADM Table 2-24 line 14

15 ksi – tension ADM Table 2-24 line 2

Maximum allowable moment on picket = 15 ksi · 0.022 in³ = 330 in-lb

Maximum span = 330 in-lb · 4/25 lb = 52.8" – concentrated load or

uniform load $(330 \text{ in-lb} \cdot 8 / 0.783 \text{ lb/in})^{1/2} = 58 \text{ in}$

Connections

#10 screw in to top and bottom infill pieces. Shear strength =

$$2 \times F_{upost} \times \text{dia screw} \times t_{rail} \times SF \quad \text{ADM Eq 5.4.3-2}$$

$$V = 38 \text{ ksi} \cdot 0.19'' \cdot 0.1'' \cdot \frac{1}{3} = 240\#$$

3 (FS)

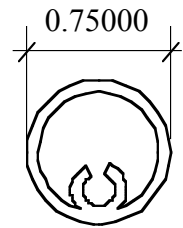

EDWARD C. ROBISON, PE

10012 Creviston Dr NW

Gig Harbor, WA 98329

253-858-0855/Fax 253-858-0856 elrobison@narrows.com

PICKETS 3/4" SQUARE

Loading → 25 psf → 4 1/2" O.C → 25psf · 375=9.4 plf

$$M = \frac{9.4/12 (42''-6'')^2}{8} = 127 \text{ lb-in}$$

or concentrated = 50# on 1 sf

For 3/4 square pickets $t=0.062'' \rightarrow$
 $S=0.05\text{in}^3$
 $f_b = \frac{127 \text{ lb-in}}{0.05\text{in}^3} = 2,538 \text{ psi}$

For 50 lb conc load → 1 SF - min 2 pickets

$$M = \frac{50/2 \cdot 36''}{4} = 225 \text{ lb-in}$$

$$f_b = \frac{225 \text{ lb-in}}{0.05 \text{ in}^3} = 4,500 \text{ psi}$$

$F_b = 15 \text{ ksi}$ – compression ADM Table 2-24 line 14
 15 ksi –tension ADM Table 2-24 line 2

Maximum allowable moment on picket = 15 ksi *0.05 in³ = 750 in-lb
 Maximum span = 750 in-lb*4/25 lb = 120" – concentrated load or
 $(750\text{inlb} \cdot 8/0.783 \text{ lb/in})^{1/2} = 87.5 \text{ in}$ - controls

Connections

Pickets to top and bottom rails direct bearing for lateral loads –ok
 #10 screw in to top and bottom infill pieces. Shear strength =

$$V = \frac{2 \times F_{upost} \times \text{dia screw} \times t_{rail} \times SF}{3 (FS)} \text{ ADM Eq 5.4.3-2}$$

$$V = \frac{30 \text{ ksi} \cdot 0.19'' \cdot 0.1'' \cdot 1}{3 (FS)} = 190\#$$

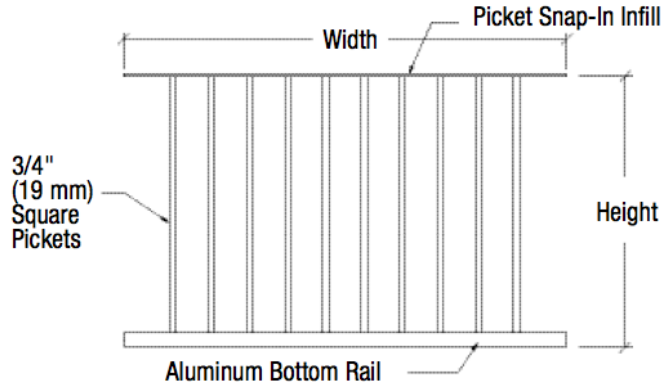

Area: 0.288 sq in
Perim: 6.03 in

Ixx: 0.0196 in⁴
Iyy: 0.0190 in⁴
Kxx: 0.261 in
Kyy: 0.257 in

Cxx: 0.392 in
Cyy: 0.376 in
Sxx: 0.050 in³
Syy: 0.051 in³

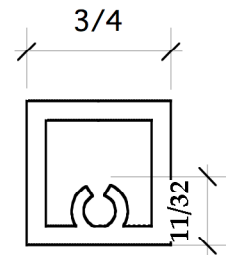

PICKET

GRAB RAIL BRACKET

Loading 200 lb concentrated load or
50 plf distributed load

Grab rail bracket – 1-7/8” long

Aluminum extrusion 6063-T6

Allowable load on bracket:

Vertical load:

Critical point @ 1.8” from rail to root of double
radius, $t = 0.25$ ”

$$M = P \cdot 1.8 \text{” or } WS \cdot 1.8 \text{”}$$

where $P = 200\#$, $W = 50 \text{ plf}$ and

$S =$ tributary rail length to bracket.

Determine allowable Moment:

$$F_T = 20 \text{ ksi}, F_C = 20 \text{ ksi}$$

From ADM Table 2-24

$$S_V = 1.875 \text{”} \cdot 0.25^2 / 6 = 0.0195 \text{ in}^3$$

$$M_{Vall} = 0.0195 \text{ in}^3 \cdot 20 \text{ ksi} = 390 \text{”}\cdot\#$$

Determine allowable loads:

For vertical load:

$$P_{all} = 390 \text{”}\cdot\# / 1.8 \text{”} = 217 \#$$

$$S_{all} = 217 \# / 50 \text{ plf} = 4 \text{’}4 \text{”}$$

Vertical loading will control bracket strength.

Allowable load may be increased proportionally by increasing the bracket length.

$$\text{For 5’ Post spacing: } 5 \text{’} / 4.33 \text{’} \cdot 1.875 \text{”} = 2.165 \text{”} - 2 \text{’}11 \text{’} / 64 \text{”}$$

Grab rail connection to the bracket:

Two countersunk self drilling #8 or #10 screws into 1/8” wall tube

$$\text{Shear} - F_u D t / 3 = 30 \text{ ksi} \cdot 0.164 \text{”} \cdot 0.125 \text{”} / 2.34 \cdot 2 \text{ screws} = 525 \# \text{ (ADM 5.4.3)}$$

$$\text{Tension} - 1.2 D t F_{ty} / 3 = 1.2 \cdot 0.164 \text{”} \cdot 0.125 \text{”} \cdot 25 \text{ ksi} \cdot 2 \text{ screws} / 2.34 = 525 \#$$

Safety Factor = 2.34 for guard rail application.

For residential installations only 200# concentrated load is applicable.

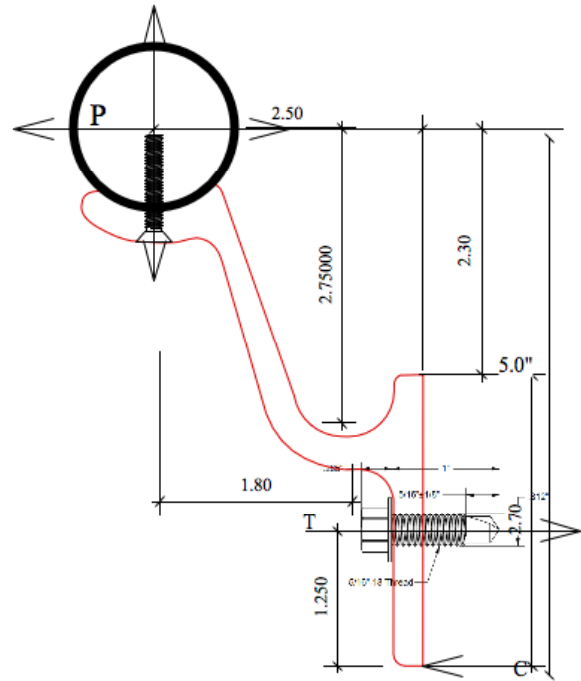

EDWARD C. ROBISON, PE

10012 Creviston Dr NW

Gig Harbor, WA 98329

253-858-0855/Fax 253-858-0856 elrobison@narrows.com

Connection to support:

Maximum tension occurs for outward

Horizontal force = 200#:

Determine tension from $\sum M$ about C

$$0 = P * 5'' - T * 0.875''$$

$$T = 200 * (5 - 1.25) / 1.25 = 600\#$$

From \sum forces – no shear force in anchor occurs from horizontal load

Vertical force = 200#+17# (DL):

Determine tension from $\sum M$ about C

$$0 = P * 2.5'' - T * 1.25''$$

$$T = 217 * 2.5 / 1.25 = 434\#$$

From \sum forces – $Z = P = 217\#$

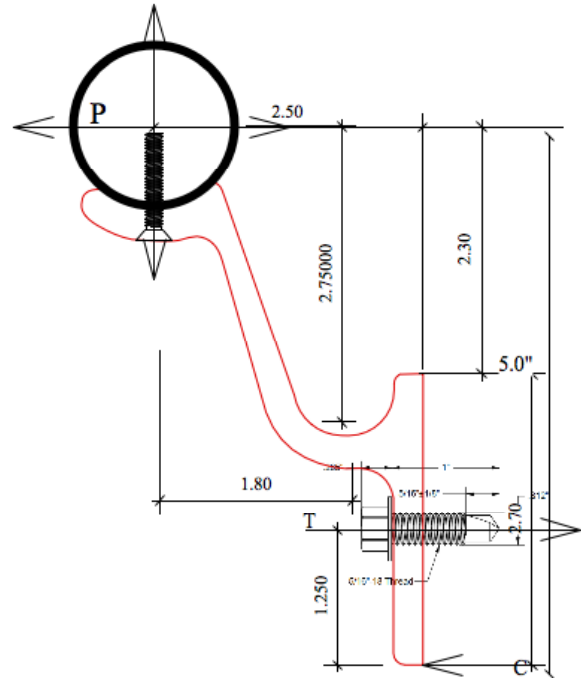

CONNECTION TO STANDARD POST (0.1" WALL)

For 200# bracket load:

For handrails mounted to 0.1" wall thickness aluminum tube.

1/4" self drilling hex head screw at post screw slot - effective thickness = 0.125"

Safety Factor = 2.34 for guard rail application.

Shear – $F_{tu}Dt/2.34$ (ADM 5.4.3)

$$38\text{ksi} * 0.2496'' * 0.125'' / 2.34 = 507\#$$

Tension – Pullout ADM 5.4.2.1

$$P_t = 0.58 A_{sn} F_{tu}(t_c) / 2.34 =$$

$$0.58 * 0.682 * 38\text{ksi}(0.10) / 2.34 = 642\#$$

Required attachment strength

$$T = 434\# \text{ and } V = 217\# \text{ or}$$

$$T = 600\# \text{ and } V = 0$$

For combined shear and tension (Vertical load case)

$$(T/P_t)^2 + (V/Z_a)^2 \leq 1$$

$$(434/642)^2 + (217/508)^2 = 0.639 \leq 1$$

Or

$$(434/642) + (217/508) = 1.10 \leq 1.2$$

Or

$$600 \leq 642\# \text{ therefore okay}$$

EDWARD C. ROBISON, PE

10012 Creviston Dr NW

Gig Harbor, WA 98329

253-858-0855/Fax 253-858-0856 elrobison@narrows.com

GRAB RAIL -1-1/2" x 1/8" WALL**6063-T6 Aluminum**

Pipe properties:

O.D. = 1.50"

I.D. = 1.25", t = 0.125"

A = 0.540 in²I = 0.129 in⁴S = 0.172 in³

Allowable stresses from ADM Table 2-24

 $F_{bt} = 18.0 \text{ ksi}$; $R_b/t = 0.625/0.125 = 5 < 35$; $F_{bc} = 18.0 \text{ ksi}$ $M_a = S * F_y = 0.172 * 18 \text{ ksi} = 3,096 \text{''#} = 258.0 \text{'#}$

Allowable Span:

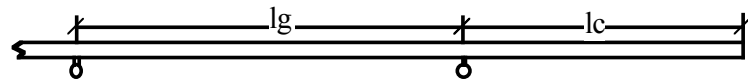
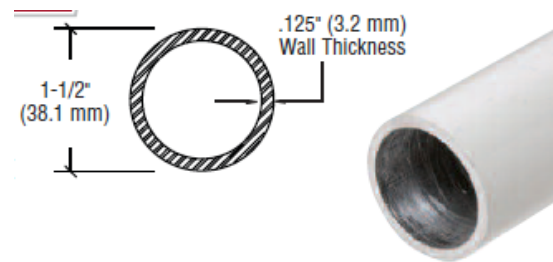
Check based on simple span and
cantilevered section. $M = w(lg)^2/8$ or $= P(lg)/4$ Solve for lg : $lg = (8M/w)^{1/2} = [8*(258.0 \text{'#}/50 \text{plf})]^{1/2} = 6.425 \text{'}$ or $lg = (4M/P) = 4*258.0 \text{'#}/200 \text{#} = 5.16 \text{'}$

Maximum allowable span for supports at both ends = 5'-1 15/16" - Controlling span

For cantilevered section

 $M = w(lc)^2/2$ or $= P(lc)$ Solving for lc $lc = (2M/w)^{1/2} = (2*258.0 \text{'#}/50 \text{plf})^{1/2} = 3.212 \text{'}$ or $lc = M/P = 258 \text{'#}/200 \text{#} = 1.29 \text{'}$ = 1' - 3 1/2" ----- Controlling spanLocate splice within lc of a support.

EDWARD C. ROBISON, PE

10012 Creviston Dr NW

Gig Harbor, WA 98329

253-858-0855/Fax 253-858-0856 elrobison@narrows.com

GRAB RAIL -1-1/2" x 1/8" WALL**Stainless Steel**

Pipe properties:

O.D. = 1.50"

I.D. = 1.25", t = 0.125"

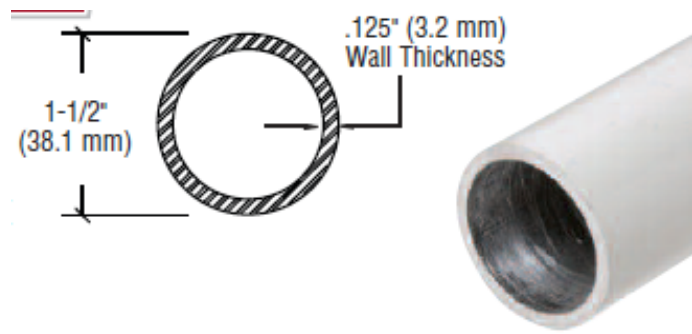
A = 0.540 in²I = 0.129 in⁴S = 0.172 in³Z = 0.236 in³ minimumr = 0.488 in, J = 0.255 in⁴

Stainless steel tube in accordance with ASTM A554-10

Rail Service Loading:

Brushed stainless steel, $F_y \geq 45$ ksi, $F_u \geq 91$ ksi (Requires Mill Certification Tests) $\phi M_n = 0.9 * 1.25 * S * F_y = 0.9 * 1.25 * 0.172 * 45$ ksi $\phi M_n = 8,707.5$ # $M_1 = \phi M_n / 1.6 = 5,442.2$ # = 453.52 #

Allowable Span:

Check based on simple span and cantilevered section.

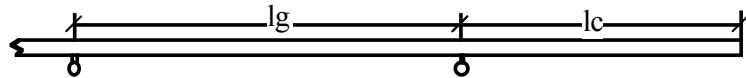
 $M = w(lg)^2/8$ or $= P(lg)/4$ Solve for lg : $lg = (8M/w)^{1/2} = [8 * (453.52 \text{ #} / 50 \text{ plf})]^{1/2} = 8.518$ ' or $lg = (4M/P) = 4 * 453.52 \text{ #} / 200 \text{ #} = 9.07$ '

Maximum allowable span for supports at both ends = 8'-6 3/16" - Controlling span

For cantilevered section

 $M = w(lc)^2/2$ or $= P(lc)$ Solving for lc $lc = (2M/w)^{1/2} = (2 * 453.52 \text{ #} / 50 \text{ plf})^{1/2} = 4.259$ ' or $lc = M/P = 453.52 \text{ #} / 200 \text{ #} = 2.268$ ' = 2' - 3 3/16" ----- Controlling spanLocate splice within lc of a support.

EDWARD C. ROBISON, PE

10012 Creviston Dr NW

Gig Harbor, WA 98329

253-858-0855/Fax 253-858-0856 elrobison@narrows.com

STAINLESS STEEL CABLE IN-FILL:

S: MAX. 6 FT. O.C. SPACING POSTS

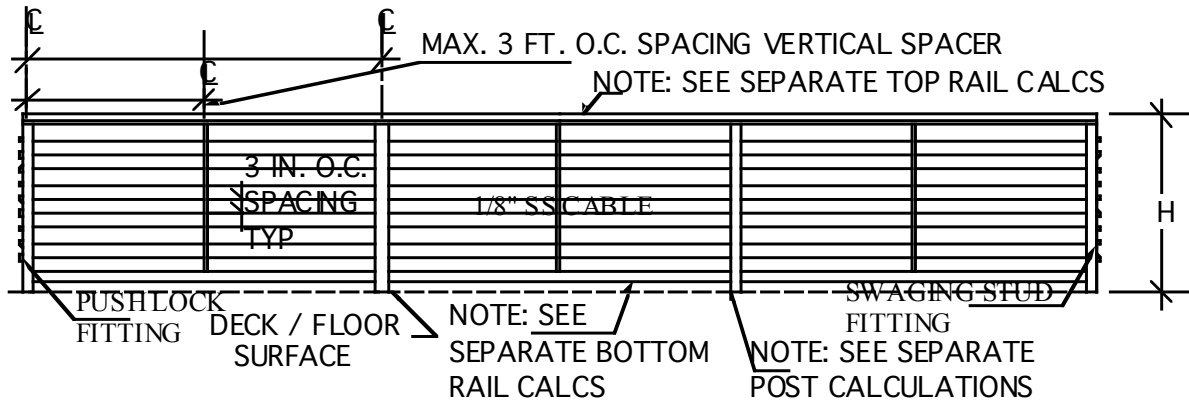

Cable railing- Deflection/ Preload/ Loading relationship

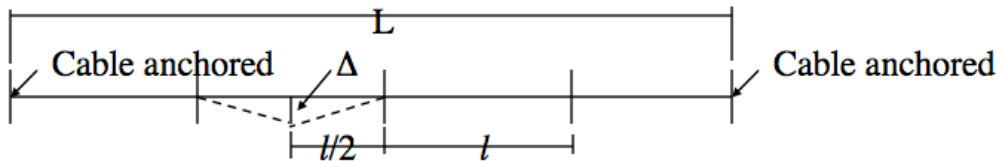

$$\text{Cable Strain} = \epsilon = \frac{C_{ta} \cdot L}{A \cdot E}$$

$$C_t = C_{ti} + C_{ta} \quad C_{ti} = \text{installation tension}$$

$$C_{ta} = \frac{\epsilon EA}{L} = \text{Cable tension increase from loading}$$

From cable theory

$$C_t = \frac{l \cdot p}{4\Delta} \quad \text{for concentrated load}$$

To calculate allowable load for a given deflection:

Calculate $\epsilon = [((l/2)^2 + \Delta^2)^{1/2} \cdot 2 - l]$

Then calculate $C_{ta} = \frac{\epsilon AE}{L}$

Then calculate $C_t = C_{ti} + C_{ta}$

Then calculate load to give the assumed Δ for concentrated load

$$P = \frac{C_t 4\Delta}{l}$$

EDWARD C. ROBISON, PE

10012 Creviston Dr NW

Gig Harbor, WA 98329

253-858-0855/Fax 253-858-0856 elrobison@narrows.com

For uniform load – idealize deflection as triangular applying cable theory

$$C_t = \frac{WL^2}{8\Delta}$$

Solving for $W = \frac{C_t 8 \Delta}{l^2}$

See spreadsheet pages based on 36' maximum cable length and 3" clear cable spacing.

Cable rail loading requirements

UBC table 16-B Line 9

Guardrail components 25 psf over entire area

IBC 1607.7.1.2 Components

50 lbs Conc. load over 1 sf

Application to cables

-Uniform load = $\frac{25 \text{ psf} \cdot 3''}{12''} = 6.25 \text{ plf}$

-Concentrated load 1 sf
3 cables minimum
 $50/3 = 16.7 \text{ lbs on } 4'' \text{ sphere}$

Produces 8.63 lb upward and downward on adjacent cables.

Deflection – since cables are 3" O.C. and maximum opening width = 4"

for 1/8" cable $\Delta_{all} = 4'' - (3 - 1/8) = 1 \ 1/8''$

for 3/16" cable $\Delta_{all} = 4'' - (3 - 3/16) = 1 \ 3/16''$

Cable Strain:

$$\epsilon = \sigma/E \text{ and } \Delta_L = L \epsilon$$

$$\Delta_L = L(T/A)/E = L(T/0.0276 \text{ in}^2)/26 \times 10^6 \text{ psi}$$

Maximum cable free span length = $60.5''/2 - 2.375'' = 27.875''$

Additionally cable should be able to safely support 200 lb point load such as someone standing on a cable. This is not a code requirement but is recommended to assure a safe installation.

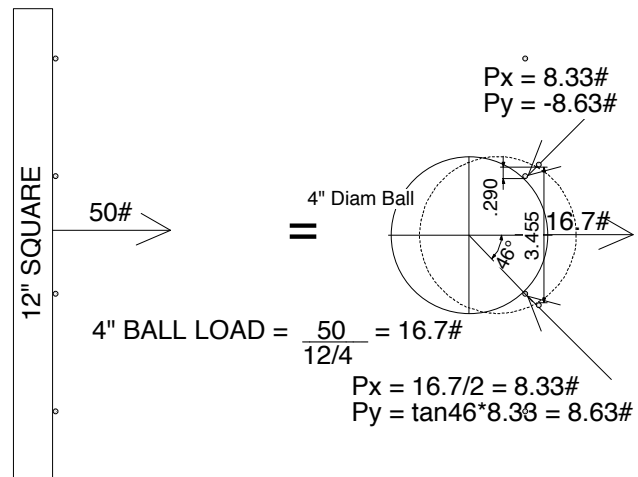

EDWARD C. ROBISON, PE

10012 Creviston Dr NW

Gig Harbor, WA 98329

253-858-0855/Fax 253-858-0856 elrobison@narrows.com

Cable railing					
Cable deflection calculations					
Cable = 1/8" dia (area in ²) =		0.0123			
Modulus of elasticity (E, psi) =		26000000			
Cable strain = Ct/(A*E) *L(in) = additional strain from imposed loading					
Cable installation load (lbs) =		150			
Total Cable length (ft) =		36			
Cable free span (inches) =		35			
Calculate strain for a given displacement (one span)				Imposed Cable load giving displ.	
delta (in)	strain (in)	Ct net (lb)	Ct tot (lbs)	Conc. Load (lb)	Uniform ld (plf)
0.25	0.00357	2.6	152.6	4.4	3.0
0.375	0.00803	5.9	155.9	6.7	4.6
0.55	0.01728	12.8	162.8	10.2	7.0
0.75	0.03213	23.7	173.7	14.9	10.2
1	0.05710	42.2	192.2	22.0	15.1
2	0.22783	168.3	318.3	72.7	49.9
2.5	0.35534	262.4	412.4	117.8	80.8
3.13	0.55542	410.2	560.2	200.4	137.4

Cable railing					
Cable deflection calculations					
Cable = 1/8" dia (area in ²) =		0.0123			
Modulus of elasticity (E, psi) =		26000000			
Cable strain = Ct/(A*E) *L(in) = additional strain from imposed loading					
Cable installation load (lbs) =		200			
Total Cable length (ft) =		36			
Cable free span (inches) =		35			
Calculate strain for a given displacement (one span)				Imposed Cable load giving displ.	
delta (in)	strain (in)	Ct net (lb)	Ct tot (lbs)	Conc. Load (lb)	Uniform ld (plf)
0.25	0.00357	2.6	202.6	5.8	4.0
0.375	0.00803	5.9	205.9	8.8	6.1
0.55	0.01728	12.8	212.8	13.4	9.2
0.75	0.03213	23.7	223.7	19.2	13.1
1	0.05710	42.2	242.2	27.7	19.0
2	0.22783	168.3	368.3	84.2	57.7
2.5	0.35534	262.4	462.4	132.1	90.6
3.02	0.51734	382.1	582.1	200.9	137.8

EDWARD C. ROBISON, PE

10012 Creviston Dr NW

Gig Harbor, WA 98329

253-858-0855/Fax 253-858-0856 elrobison@narrows.com

Cable induced forces on posts:

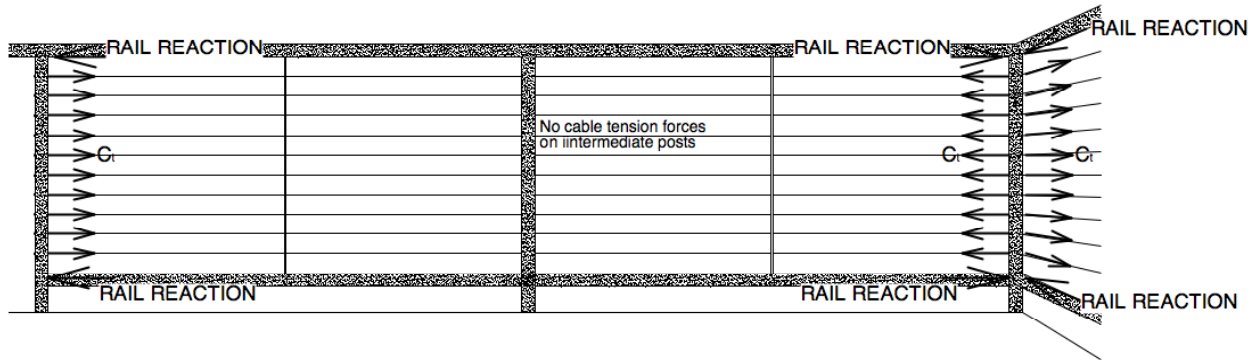

Cable tension forces occur where cables either change direction at the post or are terminated at a post.

Top rail acts as a compression element to resist cable tension forces. The top rail infill piece inserts tight between the posts so that the post reaction occurs by direct bearing.

For 400 Series top rail no infill is used. Top rail extrusion is attached to post with (6) #8 screws in shear with total allowable shear load of $6 \times 325\# = 1,950\#$

Up to eight #8 screws may be used on a post if required to develop adequate shear transfer between the post and the 400 series top rail.

Bottom rail when present will be in direct bearing to act as a compression element.

When no bottom rail is present the post anchorage shall be designed to accommodate a shear load in line with the cables of $7 \times 205\# \times 1.25 = 1,784\#$

End post Cable loading

Cable tension - 200#/ Cable no in-fill load

$$w = \frac{200\#}{3''} = 66.67\#/in \quad M_w = \frac{(39'')^2 \cdot 66.67\#/in}{8} = 12,676\#''$$

Typical post reactions for 200# installation tension :

11 cables $\times 200\# / 2 = 1100\#$ to top and bottom rails

For loaded Case

- 3 Cables @ center 220.7# ea based on 6' o.c. posts, 35" cable clear span
post deflection will reduce tension of other cables.

$$\Delta = [Pa^2b^2/(3L)+2Pa(3L^2-4a^2)/24]/EI =$$

$$\Delta = [220.7 \times 15^2 \times 24^2 / (3 \times 39) + 220.7 \times 15(3 \times 39^2 - 4 \times 15^2) / 24] / (10,100,000 \times 0.863) = 0.086''$$

EDWARD C. ROBISON, PE

10012 Creviston Dr NW

Gig Harbor, WA 98329

253-858-0855/Fax 253-858-0856 elrobison@narrows.com

Cable tension reduction for deflection will go from 200 at end cables to 271-220.7 at center,
linear reduction = $(200-50.3)/(39/2) = 7.7$ pli

$$M_{\text{conc}} = 220.7\# \cdot 15''/2 + 220.7\# \cdot 18'' + (3 \cdot (200-7.7 \cdot 3)) + (6 \cdot (200-7.7 \cdot 6)) + (9 \cdot (200-7.7 \cdot 9)) + 12 \cdot (200-7.7 \cdot 12) + 15 \cdot (200-7.7 \cdot 15)/2$$

$$M_{\text{conc}} = 10,183\#''$$

Typical post reactions for 200# installation tension with 50# infill load:

11 cables * 200# / 2 + 3 * (221 - 200) / 2 = 1132# to top and bottom rails.

Typical post reactions for 200# installation tension with 25 psf infill load:

11 cables * 207.5# / 2 = 1,141# to top and bottom rails.

For 200 # Conc load on middle cable tension

599.2# tension, post deflection will reduce tension of other cables

$$\Delta = [Pa^2b^2/(3LEI)] = [599.2 \cdot 18^2 \cdot 21^2 / (3 \cdot 39 \cdot 10100000 \cdot 0.863)] = 0.084$$

Cable tension reduction for deflection will go from 200 at end cables to 52 at center cables, linear reduction $(200-52)/19.5'' = 7.6$ pli.

$$M_{200} = 599.2\# / 2 \cdot 18'' + (3) \cdot (200-7.6 \cdot 3) + (6) (200-7.6 \cdot 6) + (9) (200-7.6 \cdot 9) + (12) (200-7.6 \cdot 12) + (15) (200-7.6 \cdot 15) + (18) (200-7.6 \cdot 18) / 2 = 11,200\#''$$

Post strength = 13,794''#

No reinforcement required.

Standard Cable anchorage okay.

Typical post reactions for 200# installation tension with 200# infill load on center cable:

11 cables * 200# / 2 + (600# - 200) / 2 = 1,300# to top and bottom rails.

Typical post reactions for 200# tension with 200# infill load on top or bottom cable:

11 cables * 200# / 2 + (600# - 200) * 33 / 36 = 1,467# to top and bottom rails.

Verify cable strength:

$F_y = 110$ ksi Minimum tension strength = 1,869# for 1/8" 1x19 cable

$$\phi T_n = 0.85 \cdot 110 \text{ ksi} \cdot 0.0123 = 1,150\#$$

$$T_s = \phi T_n / 1.6 = 1,150\# / 1.6 = 718\#$$

Maximum cable pretension based on maximum service tension @ 200# cable load is 440#:

Δ (in)	strain (in)	Ct net (lb)	Ct tot (lbs)	Conc. Load (lb)	Uniform ld (plf)
0.19	0.00206	1.7	441.7	9.6	6.6
0.33	0.00622	5.1	445.1	16.8	11.5
2.437	0.33774	278.2	718.2	200.0	137.2

EDWARD C. ROBISON, PE

10012 Creviston Dr NW

Gig Harbor, WA 98329

253-858-0855/Fax 253-858-0856 elrobison@narrows.com

CABLE LENGTH/SPAN OPTIONS:

For a **maximum cable free span of 42"** (Maximum post spacing of 44-3/8" on center)

The Maximum allowable cable length is 36'.

Required minimum cable installation tension is 373#

Cable railing					
Cable deflection calculations					
Cable = 1/8" dia (area in ²) =	0.0123				
Modulus of elasticity (E, psi) =	26000000				
Cable strain = $Ct / (A * E) * L$ (in) = additional strain from imposed loading					
Cable installation load (lbs) =	373				
Total Cable length (ft) =	36				
Cable free span (inches) =	42				
Calculate strain for a given displacement (one span)				Imposed Cable load giving displ.	
delta (in)	strain (in)	Ct net (lb)	Ct tot (lbs)	Conc. Load (lb)	Uniform ld (plf)
0.25	0.00298	2.2	375.2	8.9	5.1
0.375	0.00670	4.9	377.9	13.5	7.7
0.55	0.01440	10.6	383.6	20.1	11.5
0.75	0.02678	19.8	392.8	28.1	16.0
1	0.04759	35.2	408.2	38.9	22.2
2	0.19005	140.4	513.4	97.8	55.9
2.5	0.29657	219.0	592.0	141.0	80.6
3.03	0.43493	321.2	694.2	200.3	114.5

EDWARD C. ROBISON, PE

10012 Creviston Dr NW

Gig Harbor, WA 98329

253-858-0855/Fax 253-858-0856 elrobison@narrows.com

For a **maximum cable length of 60'**.

Maximum cable free span is 35"

Required minimum cable installation tension is 349#.

Intermediate tensioning device is required (turnbuckle or similar device).

Cable railing					
Cable deflection calculations					
Cable = 1/8" dia (area in ²) =	0.0123				
Modulus of elasticity (E, psi) =	26000000				
Cable strain = $Ct / (A * E) * L$ (in) = additional strain from imposed loading					
Cable installation load (lbs) =	349				
Total Cable length (ft) =	60				
Cable free span (inches) =	35				
Calculate strain for a given displacement (one span)				Imposed Cable load giving displ.	
delta (in)	strain (in)	Ct net (lb)	Ct tot (lbs)	Conc. Load (lb)	Uniform ld (plf)
0.25	0.00357	1.6	350.6	10.0	6.9
0.375	0.00803	3.6	352.6	15.1	10.4
0.55	0.01728	7.7	356.7	22.4	15.4
0.75	0.03213	14.2	363.2	31.1	21.3
1	0.05710	25.3	374.3	42.8	29.3
2	0.22783	101.0	450.0	102.8	70.5
2.5	0.35534	157.5	506.5	144.7	99.2
3.03	0.52075	230.8	579.8	200.8	137.7

NOTE: WHEN CABLE LENGTH EXCEEDS 36' AN ADDITIONAL TENSIONING DEVICE IS REQUIRED TO TAKE UP CABLE STRAIN AND ASSURE ADEQUATE CABLE PRETENSION, WHEN LENGTH EXCEEDS 72' THREE DEVICES ARE REQUIRED.

EDWARD C. ROBISON, PE

10012 Creviston Dr NW

Gig Harbor, WA 98329

253-858-0855/Fax 253-858-0856 elrobison@narrows.com

For a **maximum cable pretension of 440#**.

Maximum allowable cable length is 98.4'.

Maximum cable free span is 35"

Two intermediate tensioning devices are required (turnbuckle or similar device).

Cable railing					
Cable deflection calculations					
Cable = 1/8" dia (area in ²) =		0.0123			
Modulus of elasticity (E, psi) =		26000000			
Cable strain = $Ct / (A * E) * L$ (in) = additional strain from imposed loading					
Cable installation load (lbs) =		440			
Total Cable length (ft) =		98.4			
Cable free span (inches) =		35			
Calculate strain for a given displacement (one span)				Imposed Cable load giving displ.	
delta (in)	strain (in)	Ct net (lb)	Ct tot (lbs)	Conc. Load (lb)	Uniform ld (plf)
0.25	0.00357	1.0	441.0	12.6	8.6
0.375	0.00803	2.2	442.2	19.0	13.0
0.55	0.01728	4.7	444.7	28.0	19.2
0.75	0.03213	8.7	448.7	38.5	26.4
1	0.05710	15.4	455.4	52.0	35.7
2	0.22783	61.6	501.6	114.6	78.6
2.5	0.35534	96.0	536.0	153.1	105.0
3.02	0.51734	139.8	579.8	200.1	137.2

EDWARD C. ROBISON, PE

10012 Creviston Dr NW

Gig Harbor, WA 98329

253-858-0855/Fax 253-858-0856 elrobison@narrows.com

For a **maximum cable pretension of 440#**.

Maximum allowable cable length is 45.2'.

Maximum cable free span is 42"

Intermediate tensioning device is required (turnbuckle or similar device).

Cable railing					
Cable deflection calculations					
Cable = 1/8" dia (area in ²) =		0.0123			
Modulus of elasticity (E, psi) =		26000000			
Cable strain = $Ct / (A * E) * L$ (in) = additional strain from imposed loading					
Cable installation load (lbs) =		440			
Total Cable length (ft) =		45.2			
Cable free span (inches) =		42			
Calculate strain for a given displacement (one span)				Imposed Cable load giving displ.	
delta (in)	strain (in)	Ct net (lb)	Ct tot (lbs)	Conc. Load (lb)	Uniform ld (plf)
0.25	0.00298	1.8	441.8	10.5	6.0
0.375	0.00670	3.9	443.9	15.9	9.1
0.55	0.01440	8.5	448.5	23.5	13.4
0.75	0.02678	15.8	455.8	32.6	18.6
1	0.04759	28.0	468.0	44.6	25.5
2	0.19005	111.8	551.8	105.1	60.1
2.5	0.29657	174.5	614.5	146.3	83.6
3.03	0.43493	255.9	695.9	200.8	114.7

EDWARD C. ROBISON, PE

10012 Creviston Dr NW

Gig Harbor, WA 98329

253-858-0855/Fax 253-858-0856 elrobison@narrows.com

For a **maximum post spacing of 60" on center with intermediate cable spreader.**

Maximum allowable cable length is 144'. (1/8" cable may not exceed this length.)

Maximum cable free span is 27.625" (Posts @ 60" on center with center picket)

Required cable pretension is 354#

Three intermediate tensioning devices are required (turnbuckle or similar device).

Cable railing					
Cable deflection calculations					
Cable = 1/8" dia (area in ²) =	0.0123				
Modulus of elasticity (E, psi) =	26000000				
Cable strain = $Ct / (A * E) * L$ (in) = additional strain from imposed loading					
Cable installation load (lbs) =	354				
Total Cable length (ft) =	144				
Cable free span (inches) =	27.625				
Calculate strain for a given displacement (one span)				Imposed Cable load giving displ.	
delta (in)	strain (in)	Ct net (lb)	Ct tot (lbs)	Conc. Load (lb)	Uniform ld (plf)
0.25	0.00452	0.8	354.8	12.8	11.2
0.375	0.01018	1.9	355.9	19.3	16.8
0.55	0.02189	4.0	358.0	28.5	24.8
0.75	0.04069	7.5	361.5	39.3	34.1
1	0.07230	13.4	367.4	53.2	46.2
2	0.28809	53.2	407.2	117.9	102.4
2.5	0.44884	82.9	436.9	158.1	137.4
2.95	0.62302	115.0	469.0	200.3	174.1

For 1/8" diameter cable:

Cable pretension, free span and total length under no circumstance shall exceed the following limits.

MAXIMUM CABLE PRETENSION SHALL NOT EXCEED 440#.

MAXIMUM CABLE FREE SPAN MAY NOT EXCEED 42".

MAXIMUM CABLE LENGTH SHALL NOT EXCEED 144'.

Cable installation parameters are dependent on each other and must be balanced for the specific installation as shown in the examples herein. When cable length increases the allowable free span decreases. When cable free span increases the allowable cable length decreases.

EDWARD C. ROBISON, PE

10012 Creviston Dr NW

Gig Harbor, WA 98329

253-858-0855/Fax 253-858-0856 elrobison@narrows.com

Cable installation instructions:

The desired cable installation tension is 200 lbs for all runs.

Cable tension is determined by the turn of the nut method:

Cables are pulled tight by hand when setting the quick connect bracket. The cable tension is increased to 200 lbs minimum by straining the cable by 0.153" (31' length). This requires 8.5 turns of the threaded terminal from the snug condition which is attained when the cable is pulled tight by hand. For every 5 feet of cable above 31' the nut shall be turned an additional 1/2 turn to achieve the required pretension. For every 5 feet of cable less than 31' the nut shall be turned 1/2 turn less to achieve the required pretension.

When installing the cables start with the lowest then go to the highest cable and alternate back and forth until all cables are installed, installing the center cable last, working from largest number down to 1 as shown in illustration.

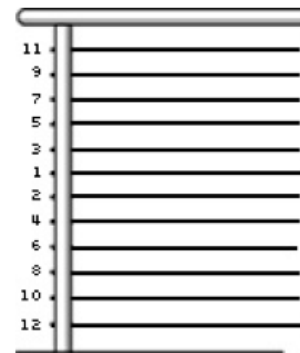
Recommended Cable Tensioning Sequence

EDWARD C. ROBISON, PE

10012 Creviston Dr NW

Gig Harbor, WA 98329

253-858-0855/Fax 253-858-0856 elrobison@narrows.com